



# Installation of steel sheet piles





---

# Installation of steel sheet piles

# Table of contents

<b>1. General</b>	<b>7</b>
<b>2. The soil</b>	<b>8</b>
2.1. Location of the construction site	8
2.2. Soil characteristics	9
2.3. Piling assessment in different types of soils	10
2.4. Choice of sheet pile section	11
<b>3. Installation equipments</b>	<b>15</b>
3.1. General information	15
3.2. Pile driving with vibration	15
3.2.1. Normal frequency vibrators	17
3.2.2. High frequency vibrators	17
3.2.3. Dimensioning of equipment	17
3.2.4. Refusal criteria	17
<b>3.3. Impact pile driving</b>	<b>18</b>
3.3.1. Diesel hammers	18
3.3.2. Driving caps	19
3.3.3. Single acting hydraulic hammers	24
3.3.4. Double acting hydraulic hammers	24
3.3.5. Fast acting hammers	25
3.3.6. Refusal criteria	27
<b>3.4. Sheet pile presses</b>	<b>27</b>
3.4.1. Self-supporting presses	29
3.4.2. Leader guided presses	30
<b>3.5. Special equipment and custom-made machinery</b>	<b>31</b>



---

<b>4. Pile driving guides</b>	<b>33</b>
4.1. General information	33
4.2. Leader guided piling	35
4.2.1. Piling with telescopic leader	35
4.2.2. Piling with fixed leader	35
4.3. Guiding frames	37
4.4. Combined walls	38
4.5. Circular cells with AS 500® sections	39
4.6. Flat cells with AS 500® sections	40
<b>5. Installation techniques</b>	<b>41</b>
5.1. General information	41
5.2. Pitch-and -drive	41
5.3. Staggered driving	42
5.4. Panel driving	43
5.5. Installing combined walls	44
5.6. "C1" and "C23" walls	47
5.7. Placing in slurry walls or mixed-in-place walls	47
5.8. Submerged piling	48
5.9. Pile driving protocols	49
5.10. Productivity assumptions	50
<b>6. Transport and storage</b>	<b>51</b>
6.1. General information	51
6.2. Transport	51
6.3. Storage	51
6.4. Shackles and lifting gear	52
6.5. Threading equipments	52
<b>7. Installation aids</b>	<b>54</b>
7.1. Water Jetting	54
7.1.1. General information	54
7.1.2. Low pressure jetting	54
7.1.3. High pressure jetting	55
7.2. Drilling	56
7.3. Cutting	57

<b>7.4. Blasting</b>	<b>57</b>
7.4.1. General information	57
7.4.2. Loosening blasting	57
7.4.3. Shock blasting	57
<b>7.5. Further practical installation hints</b>	<b>58</b>
<b>8. Pile driving accuracy</b>	<b>61</b>
<b>8.1. Installation tolerances</b>	<b>61</b>
<b>8.2. Control of wall length</b>	<b>61</b>
<b>8.3. Leaning and verticality</b>	<b>62</b>
<b>8.4. Drawing-down</b>	<b>63</b>
<b>8.5. Measurements</b>	<b>64</b>
<b>9. Special technical aspects</b>	<b>67</b>
<b>9.1. Pile driving tests</b>	<b>67</b>
<b>9.2. Working with limited headroom</b>	<b>67</b>
<b>9.3. On-site threading of multiple piles</b>	<b>69</b>
<b>9.4. Vertical load-bearing capacity</b>	<b>69</b>
<b>9.5. Noise protection</b>	<b>70</b>
<b>9.6. Vibrations</b>	<b>72</b>
9.6.1. General information	72
9.6.2. Measuring systems	73
9.6.3. Vibration assessment on humans	73
9.6.4. Vibration assessment on buildings	73
9.6.5. Vibration reduction recommendations	73
<b>9.7. Declutching detectors</b>	<b>74</b>
<b>9.8. Jagged wall</b>	<b>74</b>
<b>9.9. Inclined piling</b>	<b>75</b>
<b>9.10. Special piles</b>	<b>76</b>
9.10.1. Pipe connections	79
9.10.2. Interlocking options	80
<b>9.11. Enclosed cofferdams</b>	<b>80</b>
9.11.1. Rectangular boxes	80
9.11.2. Circular boxes	81
<b>9.12. Head and toe reinforcements</b>	<b>82</b>
<b>9.13. Piling in rock and rock dowels</b>	<b>82</b>

9.14.	Low temperature piling	83
9.15.	Interlock sealing	84
9.16.	Tie-back connections	84
9.17.	Sheet pile capping beams	85
9.18.	Measurements on existing structures	86
9.19.	Box piles	86
9.20.	Welding and butt joints	88
9.21.	Working direction of piling	88
<b>10.</b>	<b>Flat sections AS 500®</b>	<b>89</b>
10.1.	General information	89
10.2.	Storage	89
10.3.	Transport	90
10.4.	Lifting	90
10.5.	Installation procedure	90
10.5.1.	Guiding frame	90
10.5.2.	Placing the sections	90
10.5.3.	Pile driving	91
10.6.	Dismantling of cells	92
10.7.	Productivity assumptions	92
<b>11.</b>	<b>Extracting sheet piles</b>	<b>93</b>
11.1.	General information	93
11.2.	Pile preparation	93
11.3.	Extraction procedure, estimation of forces	94
11.4.	Electro-osmosis	95
11.5.	Reuse of sheet piles	95
<b>12.</b>	<b>Repair works</b>	<b>97</b>
12.1.	Deformations at pile head	97
12.2.	Interlock damages	98
<b>13.</b>	<b>References</b>	<b>99</b>
<b>Appendix A</b>		<b>101</b>
A.1.	Pile driving protocol - Impact pile driving	101
A.2.	Pile driving protocol - vibrational pile driving	102

© Picfair/ArcelorMittal



Flood protection on the Meuse in Cuijk, Netherlands

---

# 1. General

This manual is intended to be a practical guide to the successful installation of steel sheet piles. Information from construction practice and years of experience in design and site planning is presented in a brief and user-friendly way with text and pictures.

The importance of considering soil conditions, piling material, and piling equipment in relation to the respective site conditions is shown, to achieve the best technical and economical result for the given task, if necessary, by using the most suitable piling aids.

The compendium provides an overview of the current state-of-the-art piling technology, from vibratory hammers and impact hammers to hydraulic presses and the latest special equipment (status 2020, see chapter 3.5.).

The book goes on to provide a description of piling procedures, necessary and optional ancillary equipment, including piling guides, as well as an explanation of the various methods that can be used for the execution of piling works.

Where available, reference is made to further literature or relevant standards and codes.

Nevertheless, this manual does not claim to be exhaustive. And despite careful planning and preparation, soil as a construction material can always bring surprises for which new engineering solutions must be elaborated.

## 2. The soil

### 2.1. Location of the construction site

Careful site preparation is essential for the successful completion of a sheet piling job. Topographical and geological boundary conditions must be checked and documented as accurately as possible. Core-drillings together with other soil investigation methods should be foreseen as close as possible to the actual piling area. As far as geology is concerned, it should be noted that the soil as a construction material can always provide unexpected variations, even if extensive exploration has been done upfront.

Transport routes can be a decisive cost factor, depending on the length of the sheet piles. Storage areas should be available or should be prepared accordingly. Obstacles such as free hanging electric cables or underground pipelines, traffic routes or sensitive neighbouring buildings should be checked and documented before the start of construction. If necessary, a procedure for the preservation of evidence should be carried out in advance to be able to minimize the risk of later claims for eventual damages after construction is finished.

All lifting equipment should be adequately dimensioned regarding the necessary lifting heights and loads to be handled in the specified working radius.

All applicable safety regulations must be observed to ensure safe working conditions.

To assess the drivability and choose the best suitable sheet pile section, the following information should be available:

- Soil layers, as given by core drillings
- Groundwater level(s)
- Shear parameters, cohesion
- Results of CPT or SPT testing
- Weight of the soil

Furthermore, the following data can be helpful:

- Grain size, grain distribution, non-uniformity number
- Inclusions or interference zones
- Pore fraction, pore count
- Water permeability of the soil, moisture content

The more extensive the soil investigation, the lower will be any soil-related risk during execution of the job.

## 2.2. Soil characteristics

In the following tables, the relation between results from soil investigations and theoretical soil parameters is shown. The tables serve as an additional help to the designer's own empirical values.

The values for non-cohesive soils:

DPH <sub>1)</sub>	SPT <sub>2)</sub>	CPT <sub>3)</sub>	Pressure meter test		Storage Densé
			$p_l$	$E_M$	
$n_{10}$	$n_{30}$	$q_c$	$p_l$	$E_M$	
		MN/m <sup>2</sup>	MN/m <sup>2</sup>	MN/m <sup>2</sup>	
	< 4	2.5	< 0.2	1.5	very loose
3	4 to 10	2.5 to 7.5	0.2 to 0.5	1.5 to 5.0	loose
3 to 15	10 to 30	7.5 to 15	0.5 to 1.5	5.0 to 15	medium dense
15 to 30	30 to 50	15 to 25	1.5 to 2.5	15 to 25	Dense
> 30	> 50	> 25	> 2.5	> 25	very dense

<sup>1)</sup> Probing with a heavy pile driver (Dynamic Probing Heavy)

<sup>2)</sup> Standard Penetration Test (SPT)

<sup>3)</sup> Pressure probing (Cone Penetration Test)

EN ISO 14688-2 describes the condition of cohesive soils:

SPT	CPT	Pressure meter test		Designation	undrained Shear strength
		$p_l$	$E_M$		
$n_{30}$	$q_c$	$p_l$	$E_M$		$c_u$
	MN/m <sup>2</sup>	MN/m <sup>2</sup>	MN/m <sup>2</sup>		kN/m <sup>2</sup>
				extremely low	< 10
< 2	< 0.25	< 0.15	1.5	very low	10 to 20
2 to 4	0.25 to 0.5	0.15 to 0.35	1.50 to 5.25	low	20 to 40
4 to 8	up to 1.0	up to 0.55	up to 8.25	medium	40 to 75
8 to 15	up to 2.0	up to 1.0	up to 20	high	75 to 100
15 to 30	up to 4.0	up to 2.0	up to 40	very high	150 to 300
> 30	> 4.0	> 2.0	> 40	extremely high	> 300

\* SPT tests are more commonly used for non-cohesive soils.

It should be noted that each method indicates a certain range of soil definitions. Local experience or, where appropriate, test pile driving may be considered to further assess drivability.

Further information can be found in the technical information sheet "Einteilung des Baugrunds in Homogenbereiche nach VOB/C (MEH)" published by the German Federal Waterways Engineering and Research Institute (BAW) in 2017.

### 2.3. Piling assessment in different types of soils

For each soil type described in chapter 2.2., it is possible to define preferred installation methods, which are briefly described below.

#### Method: Impact pile driving

In principle applicable in any soil condition, up to weathered rock. Good installation performance in cohesive soil and hard non-cohesive soils.

Additional toe reinforcement can be considered (see chapter 9.12.).

#### Method: Pile driving with vibration – normal frequency

Sand and gravel with round grain shape as well as soft cohesive soils are particularly well suited to vibratory pile driving. In soils with sharp-edged grains and in stiff cohesive soils, a machine setup should be considered that provides a large working amplitude to open a sufficiently wide gap in the soil.

It has been observed that dry soils have a greater resistance to pile penetration than soils that are moist, submerged or completely saturated with water.

Water jetting or pre-drilling can significantly increase the installation performance.

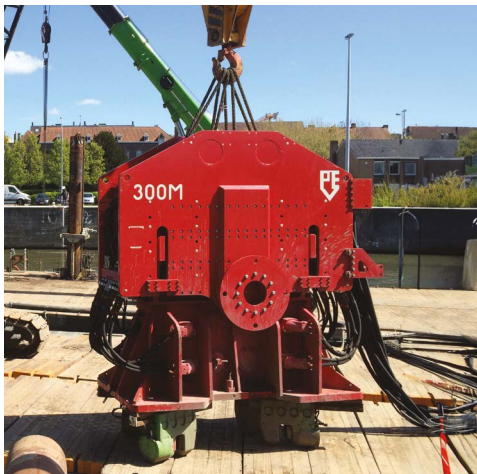

#### Method: Pile driving with vibration – high frequency with variable eccentric moment

Very suitable for non-cohesive soils and for piling near existing buildings. The working distance to neighbouring structures can be less than 1 m. Resonance vibrations are avoided due to the relatively small working amplitude and high machine frequency and the adjustable eccentric moment. The method is not very effective in stiff cohesive soils, as a strong damping effect is to be anticipated.

#### Method: Pressing

Well suited for inner-city construction sites where vibration is to be avoided. Presses can be leader-guided or self-supported on the sheet pile wall, which reduces the required necessary working space.

Best installation performance can be achieved in loose to medium dense cohesive or moist non-cohesive soils. The method can be combined well with water jetting or pre-drilling.

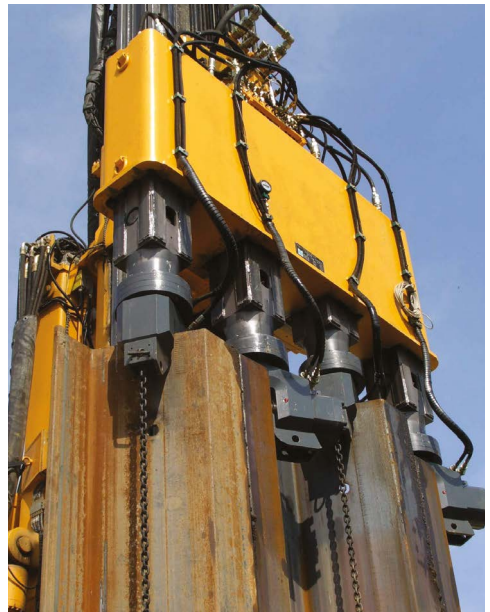



## Procedure: Placing in trench

In difficult geological conditions or in the vicinity of sensitive buildings, placing sheet piles in a cement slurry or mixed-in-place wall can be a beneficial solution. Especially for dyke reinforcements or permanent outside walls of underground car parks this method can ensure durability and watertightness for the final structure.



For the securing and encapsulating of contaminated waste sites the high watertightness of sheet piles can be combined with the corrosion protection of a bentonite cement suspension.

### 2.4. Choice of sheet pile section

Piling section, soil and piling equipment must always be considered as a combined unit in order to achieve the most economical solution for a given construction project.

The sheet pile section determined by the static calculation must be capable of being driven to the required penetration depth. The drivability of a profile is a function of its cross-sectional properties, the length, the steel grade, the driving equipment, and the driving method. The cross-sectional properties of a sheet pile depend on the wall thickness, as well as the width and depth of the profile.

The following diagram shows the empirical relation between soil properties, pile length and section modulus. By using the curves, the designer can quickly check if the selected section meets the installation requirements.

The following rule of thumb can always be considered: "The recommended maximum length of the sheet pile profile (in cm) corresponds to the elastic section modulus (in  $\text{cm}^3 / \text{m}$ )".

The larger the surface area of the profile, the more energy is required for pile driving. To avoid energy loss due to excessive movement ("wobbling") of the pile, care must be taken to ensure that the profile selected is suitable for the given ground conditions and offers sufficient stiffness to transmit the pile driving energy to the toe of the pile. To install the wider AU and AZ profiles, the use of a double clamping system is highly recommended.

Depending on the type of section, in most cohesive and certain non-cohesive soils, plugging will occur at the end of the pile. The wider the profile is, the less the tendency to plug occurs.

The necessary pile-driving energy is highly dependant on the ground conditions. This means that there is a limit to the drivability of a selected profile in the designed steel grade. With a higher steel grade, the admissible stress that can be absorbed, also increases. This results in a higher resistance to head and toe deformation.

If pile driving is carried out at low temperatures (lower than  $-5^{\circ}$ ), special care must be taken (see 9.14).

The soil layers and the associated parameters should be considered in such a way that, in general, the hardest layer is used as a reference for the expected pile driving resistance.

The installation of combined walls always demands special considerations, as different boundary conditions prevail here: generally, the king piles are driven first.

Once installed they will act as a guide on both sides for the intermediate piles. The intermediate piles are generally shorter (60–80%), which facilitates installation. Z-piles are generally the preferred intermediate pile type, as the position of the middle interlock allows significant rotation and thus adaptation to the position of the already driven king piles. U-piles are rather inflexible because of the interlock position and thus are immediately subjected to tension in the longitudinal axis of the profile.

If pile driving is to be carried out in rock, appropriate measures should be taken into consideration at the planning phase. A sufficiently stiff profile, foot reinforcements and/or pre-drilling can be mentioned here.

Circular cells are considered separately in chapter 10.

Various computer programs exist today that simulate the pile driving process. They are reasonably accurate for installation with percussive equipment, but further research is needed for installation with vibratory hammers.

## Pile length - m

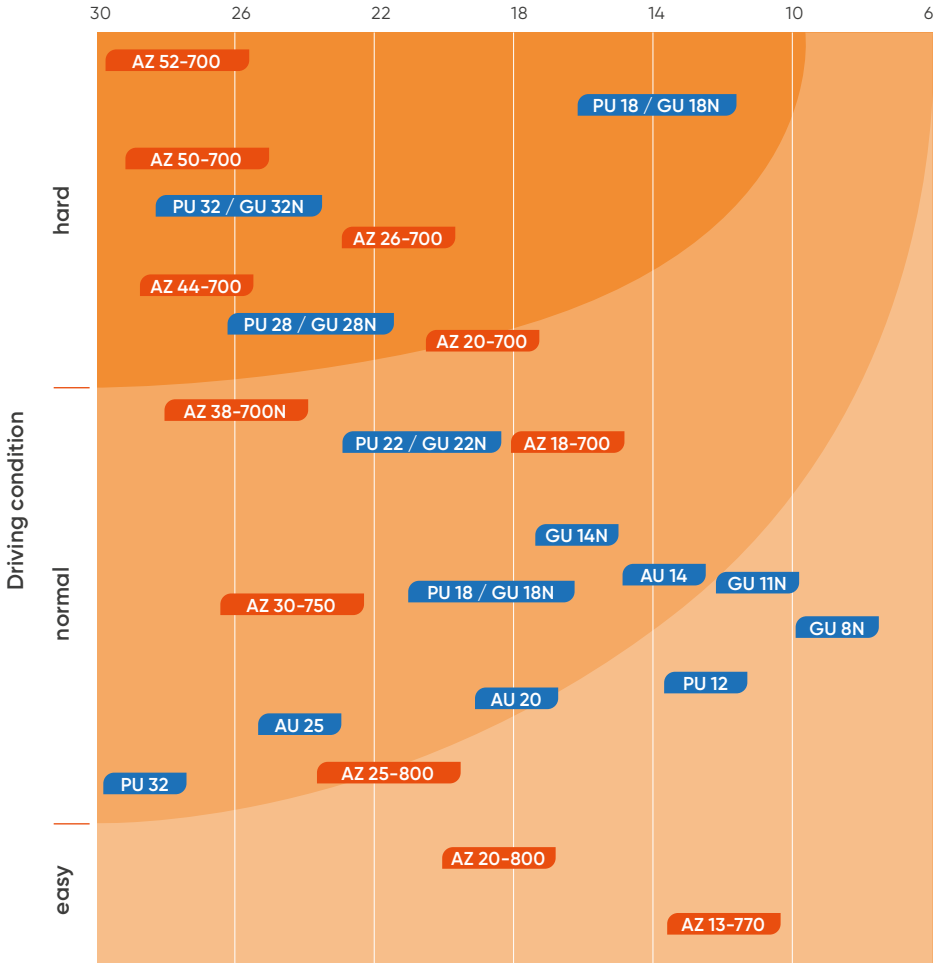



## 3. Installation equipments

### 3.1. General information

Selecting the correct equipment is of fundamental importance for the success and safe progress of a sheet pile job site. Today equipment technology offers a wide range of vibratory hammers, impact hammers and pressing machines, so it is possible to choose the most suitable equipment to meet the demands of the given task.

All installation equipment can be used either freely suspended from a crane or guided by a leader mast.

When a leader is used, the operator has utmost control on the accuracy of pile verticality and plan position, so the use of a simple guiding frame on the ground is recommended. The disadvantage is the limited working radius of the machine.

If working freely suspended from the crane, the working radius depends on the lifting capacity and mast length of the lifting equipment. A 2-level guiding frame should be used to make sure that the piles are installed within the required contractual tolerances.

### 3.2. Pile driving with vibration

Nowadays vibratory pile driving is the most common installation technique. With modern equipment it is possible to work in inner-city areas without creating disturbance. By using high-frequency vibratory hammers with variable eccentric moment and adjustable hydraulic flow it is possible to eliminate nearly all vibrations towards neighbouring buildings. Normal-frequency vibrators are designed in such a way that even very stiff cohesive soil layers can be penetrated.

The principle of vibrating is to reduce the friction and peak resistance between sheet pile and soil during vibration. The vibrations temporarily put the soil around the pile into a pseudo-liquid state, resulting in a noticeable reduction of the penetration resistance.

This makes it possible to lower the pile with a small additional force - i.e. under its own weight plus weight of the vibrator - into the soil. With leader-guided machines, an additional external load can be applied by the pull-down force of the machine.

The vibrations are generated by eccentric weights being accelerated by one or more motors via a gearbox. When resonance-free machines are used, a number of parallel eccentric weights rotate with the same frequency but in opposite directions, which cancels out the horizontal component of the rotating forces and only the vertical force component remains effective. Vibrators are driven by hydraulic motors, electric motors, or a combination of these. Hydraulic clamps, that are fixed beneath the vibrator, ensure secure fixing and energy transmission into the sheet pile. The vibrator housing is shielded





by a damping block upwards or sideways to make sure vibrations are not transmitted to the crane or base carrier machine.

If an excavator-mounted vibrator is used, the minimum power outlet and the minimum weight of the basic unit must be observed in accordance with the manufacturer's specifications. Overloading due to lack of engine power or overly heavy piles should be avoided. Generally, excavator-mounted vibrators are used for small temporary works. Equipment with "side-grip" capability allow flexible and fast working cycles even in confined spaces.

In modern hydraulic vibrators, the vibration frequency can be changed easily. The system can thus be adapted to changing ground conditions. Submerged working is generally

possible; any special modification should be checked with the respective manufacturer.

Vibrators can be used very effectively for extracting sheet piles. The vibration reduces the resistance between the soil and the sheet pile and extracting can be carried out with relatively low static force. The topic of recovering installed sheet piles is discussed in detail in chapter 11.

The vibrators are classified by their working frequency. To correctly assess the performance of a machine, the centrifugal force and the eccentric moment must be considered.

In general, the choice of sufficiently dimensioned clamps is essential for successful installation progress. The clamping force should be at least 1.2 times the



Excavator-mounted vibrator



Side-grip vibrator



Example of a triple U-pile clamp with special turning plate

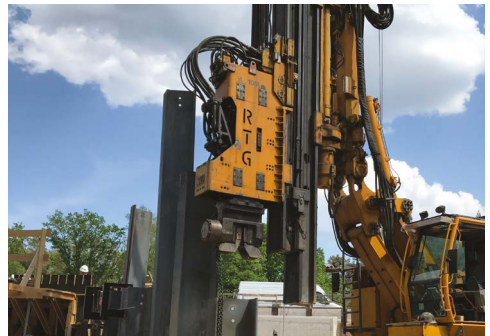

Standard single clamp

centrifugal force of the vibrator. The friction surfaces of the clamps must be sufficiently large and excessively worn clamping equipment should be replaced over time, to prevent damage to the sheet pile or the equipment.

For wide Z- and double U-piles, corresponding double clamps are recommended turning plates to guarantee correct fitting are available at the equipment manufacturers. Special clamp arrangements for multiple piles are possible. In the case of double or multiple pile installation, it is recommended to fix at least the head of the piles by crimping or welding to avoid damage introduced by relative movements of the piles under the machine, for example due to obstacles in the ground.

### 3.2.1. Normal frequency vibrators

Standard vibrators operate in a frequency range between 800 and about 2000 revolutions per minute. Centrifugal forces can reach as much as 8000 to 10000 kN, and combined machine configurations allow up to 32000 kN, used for example in offshore construction. For sheet piling work, machines up to 4000 kN are usually in service.

The advantage of a normal frequency vibro hammer is the large working amplitude, which is achieved by a large eccentric moment. Dense non-cohesive soils and stiff cohesive layers can be easily penetrated. Since the resonance frequency of the soil can be hit during machine start-up, vibrations on neighbouring structures cannot be avoided. This should be already considered when planning a construction site. Some normal-frequency vibrators are available with variable eccentric moment.

### 3.2.2. High frequency vibrators

High frequency vibrators are operating at more than 2000 revolutions per minute and often have a variable eccentric moment setup. Ground vibrations generated by these machines are damped very quickly and thus do not cause any problems to neighbouring structures. Passing the resonance frequency of the ground can be completely avoided by changing the eccentricity. The eccentric moment is significantly lower compared to normal frequency vibro hammers, the required centrifugal force is generated by higher rotation speed. The working amplitude is rather small and the best working performance is achieved in non-cohesive soil. If the pile driving process is slow, care must be taken that the interlocks do not overheat. If necessary, the locks should be cooled with water.

### 3.2.3. Dimensioning of equipment

When choosing a suitable vibrator for a given job, the centrifugal force can be used as reference. The necessary machine size can be estimated with the following approximation formula:

$$F = 15 \cdot \left( t + \frac{2G}{100} \right) \cdot E \text{ [kN]}$$

F = centrifugal force	in kN
t = pile driving depth	in m
G = Mass of the sheet pile	in kg
E = Influence factor of soil (1.0 - 1.3)	

### 3.2.4. Refusal criteria

In general, a penetration speed of 50 cm per minute is considered as lower limit for vibro piling. As further criteria to stop vibrating the following can be considered: If no driving progress is achieved after 5 minutes of

continuous vibrating, the machine should be stopped to avoid damage to equipment or the pile. Cracking of the sheet pile heads due to material fatigue can thus be avoided. If the calculated required final depth has not yet been reached, it may be necessary to switch to a larger vibratory hammer, or to impact pile driving.

When selecting the piling equipment, not only the centrifugal force should be checked, but also the eccentric moment and whether the correct frequency type of vibrator is available for the existing ground conditions.

If the sheet pile interlocks are treated with sealants, other recommended penetration speeds may need to be observed.

### 3.3. Impact pile driving

#### 3.3.1. Diesel hammers

Diesel hammers are a very effective installation tool, and have been widely used for decades. The hammers fit almost all pile sizes.

First, a piston is raised to a predetermined height and then released automatically. The falling piston compresses the air in the pressure chamber and causes the fuel pump to spray fuel onto the top of the anvil. The impact of the piston on the anvil ignites the diesel fuel in the highly compressed air. The explosion energy moves the piston upwards, drives the sheet pile downwards and the hammer cycle starts again.

The diesel hammer is self-regulating. With higher resistance, the stroke height of the piston increases, and the number of strokes go down. Harmful rebound impacts due to excessive stroke heights can be avoided by selecting a sufficiently dimensioned hammer.

If pile testing is done, the number of blows and, if possible, the piston stroke should be measured to be able to assess the driving energy applied. A theoretical calculation of the pile load capacity is possible, e.g. using Hiley's formula (see chapter 9.4.).

Diesel hammers work particularly well in cohesive and very dense soils. Under normal site conditions, a ratio of 1:1 to 2:1 should be selected between the piston weight and the weight of the pile plus the driving cap. The driving cap serves as protection for the pile head and allows for effective impact energy transfer. ArcelorMittal offers a variety of driving caps for diesel hammers. If inclined pile installation is demanded, it is advisable to check the permissible working angle for the hammer. For diesel hammers, inclination of up to 1:5 is technically possible.

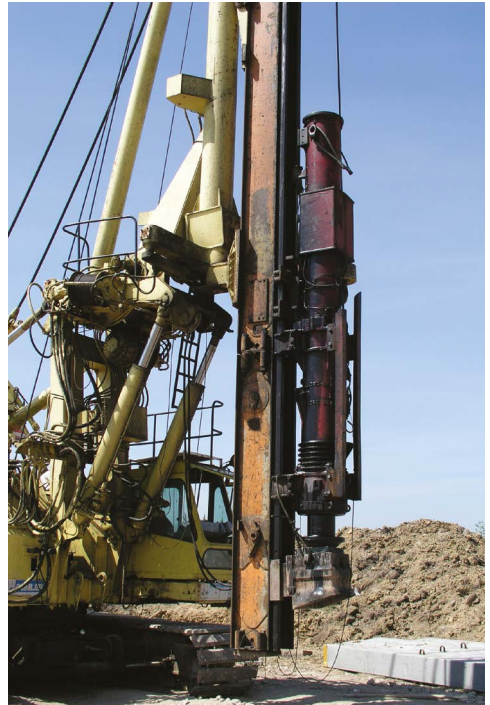

Diesel hammer mounted on a leader mast



In general, the use of vibratory pile drivers after impact pile driving is only done for extracting piles.

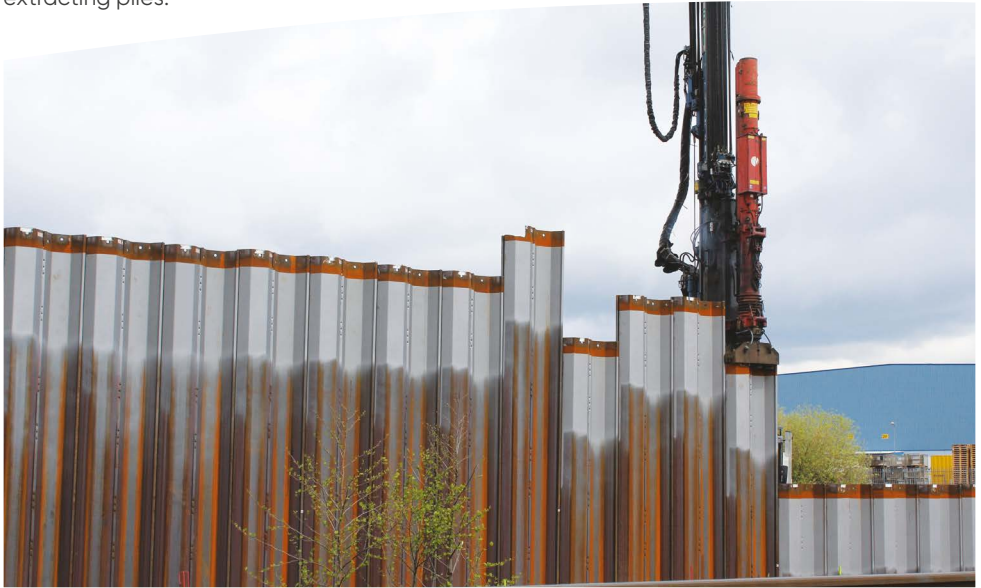

Diesel hammer mounted on a leader mast and in use within a continuous wall

### 3.3.2. Driving caps

To optimize energy transmission from the hammer to the sheet pile, a driving cap with a suitable inlay or cushion is required. The weight can range from a few hundred kilos to several tonnes. It is usually made of cast steel, but welded constructions are also possible. A cushion chamber on the top of the driving cap retains the inlays.

Guides are fitted at the bottom of the cap in the shape of the elements to be driven. The guides should be beveled towards the pile position to facilitate placement on the pile head. Single, double and triple piles can be used for U-piles; double and triple piles should be crimped or welded in the connecting interlock to avoid relative movements under the hammer. Z-piles are installed preferably as crimped or welded

double piles. The driving of single-Z piles should be avoided wherever possible. The straightness of the pile head should always be checked and re-cut if necessary. If special piles are used, it is recommended to check whether the shape fits into an existing driving cap or whether an adjustment of the pile might be necessary.

When using a leader mast, the correct distance of the sliding guide can be adjusted with the help of spacers. The cushion serves as a damper to soften the blows of the hammer and avoid bouncing-back. Generally, hardwood, steel cables or special cushion systems made of alternating layers of plastic, aluminum and steel are used as inlays.

If wood is used, the life of the cushion can be extended by placing a 20-30 mm thick steel plate on top. The plate must be secured against falling. Impacts on the steel edge of the cushion chamber must be avoided. The wood must be replaced in due course.

A special cushion system made of alternating layers of plastic and metal plates offers a longer service life than just hardwood.

When using steel ropes, an approx. 75 mm thick steel plate is advantageous as the top cover. The ropes can either be cut and inserted crosswise or they can be inserted in a circular shape to fit. Compared to the wooden infill, the stress introduced in the driving cap is higher with the other two variants; a daily inspection is recommended to check for damage over time.



Cast steel driving cap



Welded construction

For diesel hammers and single-acting hydraulic hammers, cast and welded driving caps are available from ArcelorMittal.



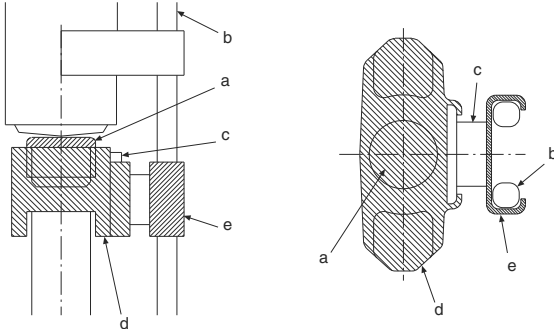

- a = Dolly/cushion
- b = Leader
- c = Sliding guide
- d = Driving cap
- e = Leader slide

The leader slide (e) is not provided by ArcelorMittal.



Driving cap under hammer



Driving cap placed on sheet pile wall

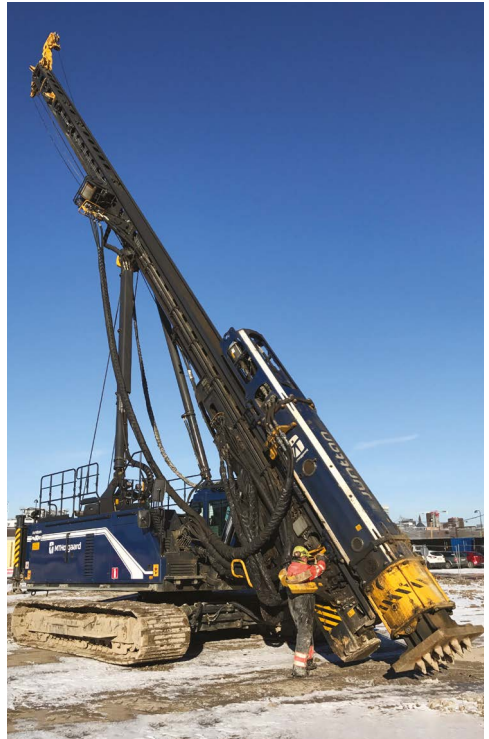

Device-specific adaptation





### 3.3.3. Single acting hydraulic hammers

The impact weight of this hammer type is guided by a support frame and lifting is done and controlled by hydraulics. After reaching the pre-set height, the impact weight falls freely by valve reversal. The hydraulic lifting process works using two pistons in the case of lateral guiding or one piston in case of direct axial lifting of the impact weight.

The hammer can be easily adapted to be used for driving different profile types. It is suitable for all soil types and can work above and below water level. The ratio of piston weight to pile weight is similar to the recommendation for diesel hammers: 1:1 up to 2:1 can be applied.

Piston weights up to 11 tonnes are available with a variable drop height reaching 1.2 m. Using maximum piston weight and maximum lifting height, a stroke rate of 40 strokes per minute can be achieved with automatic control. Special designs can be made for specific projects. For the same impact energy, the use of a heavy piston with a short stroke is always preferable.

This will help to reduce damage to the pile head and lower noise emission to a certain extent. Modern drop hammers are available silenced. Inclined piling is possible depending on the equipment, here the manufacturer's recommendations should be checked.

The hammer controls work with utmost accuracy and efficiency levels of 75-80% can be achieved with this type of hammer. All relevant information can be stored via data recorders, if the machine is equipped with a data logging system.



### 3.3.4. Double acting hydraulic hammers

This type of hammer features a closed system in which the piston is lifted by hydraulic pressure. During the downward movement, energy is applied to the piston, resulting in an additional acceleration of up to 2\*g. The maximum stroke of 1 m thus corresponds to a free fall from a height of 2 m.

Hammers of this type offer a maximum energy per stroke between 35 kNm and 3000 kNm at a blow rate of 50 to 60 strokes per minute. Electronic control systems ensure optimal pile driving results and the machine design allows for including a range of additional features for safety, monitoring and displaying. The net energy delivered to the pile is measured at each stroke and displayed on the control panel. Energy levels can be continuously adjusted within a range between maximum and minimum values of the specific unit.

Hydraulic hammers can work at any angle above and below water and are suitable for both operations: driving down and extracting piles. Considering standard site conditions, a ratio of piston weight to the weight of the pile plus driving cap of 1:2 to 1:1 should be selected.

For driving normal sheet pile walls, the use of hydraulic hammers with an energy output between 35 kNm and 90 kNm per blow is common. For king piles in combined walls the machines are generally larger, always depending on pile weight and soil conditions.

The driving caps for hydraulic hammers are specific to the equipment and can be requested from the respective manufacturer. They are usually made of high strength forged steel, as the impact energy is higher than that for of diesel hammers.



### 3.3.5. Fast acting hammers

The impact piston of a fast-acting hammer is powered by compressed air or steam during lifting and falling, although genuine steam hammers are no longer in service today.

Pressurized air or steam is used at a valve box which leads alternately to the two sides of the piston, while the opposite side is connected to the exhaust ports. As it falls, the piston hits a flat anvil attached to the cylinder, which sits on top of the pile to be driven in. The pressure then lifts the piston and accelerates it again as it falls.



Compared to drop hammers with the same total weight, the piston of a fast-acting hammer is much lighter. The weight is only 10-20% of the total weight of the hammer, but it is effectively amplified by the 5-8 bar pressure acting on the top of the piston.

The hammers are designed to be highly efficient used in conjunction with commonly available compressors. 90% of the pile driving energy comes from the action of the compressed air or steam.

The piston weight of hammers used for steel sheet piling ranges from 100 to 1300 kg, and the drop height, which normally increases with hammer weight, varies from 110 mm to 500mm. The total impact energy of the largest high-speed hammer is about 30 kNm per impact, i.e. it is much lower than the output of other large drop hammers.

On the other hand, the impact rate is higher, the hammer delivers about 100 blows per minute for large machines and 400 blows per minute for the smaller machines. The relatively high impact rate leads to a constant pile movement, which facilitates the pile driving process.

It is not advisable to place a driving cap between the hammer and the sheet pile, as this will result in a huge loss of efficiency.

High-speed hammers can also be equipped for use under water and for extracting piles. For continuous pile driving the penetration speed should be limited to 150 mm/min, while over short period of operation a speed of 50 mm/min is permissible. Normally a ratio of minimum 1:5 of piston weight to pile weight is chosen.



Air-powered fast-acting hammer



### 3.3.6. Refusal criteria

A penetration rate of 25 mm per 10 blows of the hammer, should be considered as limit for the use of diesel hammers. In any case, the hammer manufacturer's recommendations should be checked. If the corresponding refusal value is reached, either the work should be stopped or a change towards a larger hammer should be considered.

In certain circumstances, penetration of 1 mm per blow is permissible for a short period of time. Continuous working with such low progress can cause damage to hammer and sheet pile.

### 3.4. Sheet pile presses

Low-vibration installation of sheet piles with hydraulic presses has become a standard construction method in recent years. Various systems are available on the market since 1958, additional equipment such as augers or water jetting systems are available. All pressing methods have in common that first the machine is providing the reaction force, with increased installation depth the installed piles act as reaction piles for the ones to be installed.

Pressing methods are particularly effective in soft to medium stiff cohesive soils. Loose to medium- dense sands can also be pressed through. It should be noted that with wider sheet piles a higher skin friction must be considered. In case of doubt, consulting the manufacturer is recommended.

It is common practice to fill the interlocks with grease, Beltan® Plus or simple construction foam, and to close the free lock at the end of the pile with a bolt. These simple measures prevent soil particles entering the lock chamber and so help to considerably minimize interlock friction during installation. Depending on the interlock fill that is used, the material may harden at low temperatures. In this case, preheating can be a solution, or storage of piles in a frost-protected area.

During installation, the verticality of the piles should be checked precisely to avoid misalignment and thus increased installation resistance. Combined walls can only be pressed to a limited extent with auxiliary constructions.

In general, sheet piles with a length up to 17 m are suitable for pressing. Together with soil exchange and water jetting 25 m has been reached.

## Determination of the pressing force

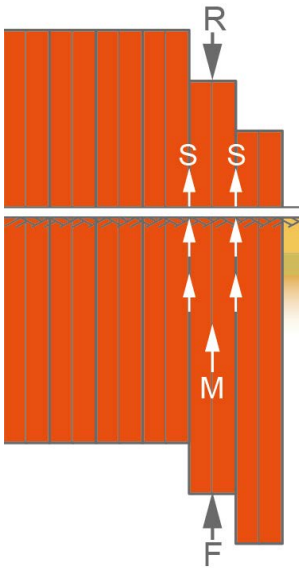

### Skin friction M

kN/m<sup>2</sup>

#### Non-cohesive soil

Pile length in the soil < 10m

40,0

Pile length in the soil > 10m

70,0

#### Cohesive soil

Pile in soft soil

15,0

Pile in hard soil

30,0

### Point resistance F

kN/m<sup>2</sup>

#### Non-cohesive soil

Pile length in the soil < 10m

3,5

Pile length in the soil > 10m

5,0

#### Cohesive soil

Piles in soft soil

1,0

Piles in hard soil

2,0

### Interlock friction S

kN/m

Very accurate installation, soft soil

10

Very accurate installation, fine sand

50

Slightly inclined installation

25

Inclined installation

40

Any Interlock lubrication

10

Approximate determination of the required pressing force R in [kN] per cylinder depending on the length and geometry of the sheet pile to be pressed:

$$R(L) = M + F + S \text{ (for one-sided interlock friction)}$$

$$R(L) = M + F + 2 \cdot S \text{ (for two-sided interlock friction)}$$

with:

M = Skin friction in kN/m<sup>2</sup>

F = Peak resistance in kN/m<sup>2</sup>

S = Interlock friction in kN/m (on both sides or on one side depending on the pressing method)

L = Length of sheet pile

The values for skin friction, point resistance and interlock friction can vary substantially depending on the actual conditions. A piling test or consulting local expertise is advisable.

### 3.4.1. Self-supporting sheet pile presses

Self-supporting presses can push single or double piles one after the other to design depth. To start, a ballasted guide frame can serve as starting point which the pile press can grip to drive the first piles be placed. The presses work completely independent of any base carrier machine. Additional equipment is available for water jetting and pre-augering to loosen hard soils, as well as a crane, which helps to reduce the job site installations to a minimum area. Circular- and corner constructions are possible with U- or Z-piles.



The sheet pile is completely pressed in.

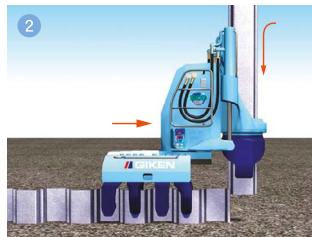

The following sheet pile is gripped by the press head.

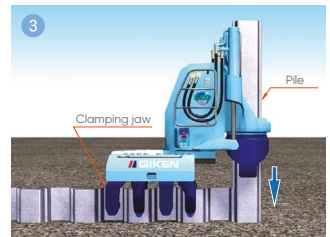

The sheet pile is pressed in for several meters until it reaches a certain stability.

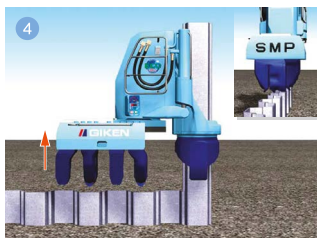

The pressing head is raised and the sheet pile is clamped. The clamping body is raised.

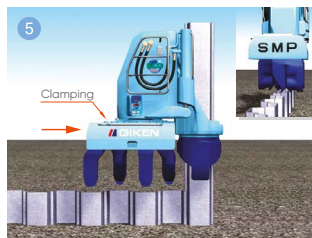

The clamping body is shifted by one pile set.

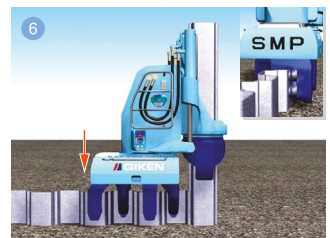

The clamping body is lowered and hydraulically adjusted. Pressing in can be continued.

Working cycle of a self-supporting sheet pile press

### 3.4.2. Leader guided sheet pile presses

A standard excavator equipped with a rigid or telescopic leader mast serves as carrier, to which either the press or a vibrator can be attached. The presses normally have 3 or 4 cylinders and develop pressing forces between 80 t and 300 t. Before installing, the sheet piles are assembled into triple or quadruple panels and fixed under the press with toggle chains. Lifting is done together with the press, leading to an optimized work cycle. The multiple panels can be easily assembled on site.

This helps to keep transport simple and cost-effective, and sealant can be filled in the interlocks on site just before the start of piling works.

Water jetting or pre-augering can be used to facilitate pile driving.

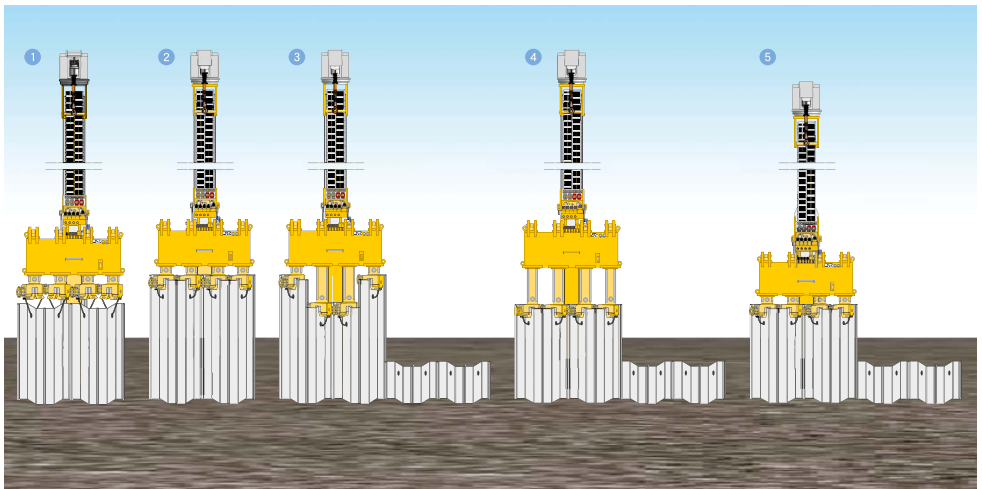

Working cycle of a leader-guided press

### 3.5. Special equipment and custom-made machinery

In addition to conventional piling equipment, numerous bespoke solutions have been developed for specific projects such as:

- Tandem vibrators
- Connected vibrator groups
- Water-based hydraulic hammers (without hydraulic oil)
- Resonance-based equipment ("Resonator");
- Rail-based piling rigs for railway projects.

Installation using the resonance method is particularly interesting, as virtually no vibrations are generated and work is made possible in inner-city areas or in areas with high risk of soil instabilities, e.g., old earth dykes. The Resonator does not use rotating eccentric weights, instead piling energy is created through a high-performance piston that converts the pile into a spring. The vertical movements of the pile open the soil and the pile can penetrate under its own weight. No horizontal waves are created.

The use of piling aids according to chapter 8. can be considered for all special machines.

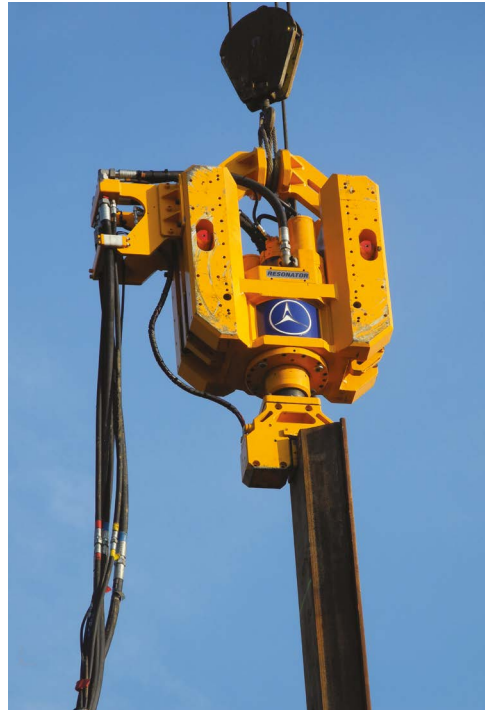

Resonator



Water-powered percussion hammer





Two-way unit with short mast for pile driving along railway lines with limited working space to sideways and upwards.



Rail-based pile driving rig.

## 4. Pile driving guides

### 4.1. General information

Correct horizontal and vertical alignment is of utmost importance when driving steel sheet piles. To ensure best installation results, the use of a piling guide is recommended, which also helps to prevent lateral movements.

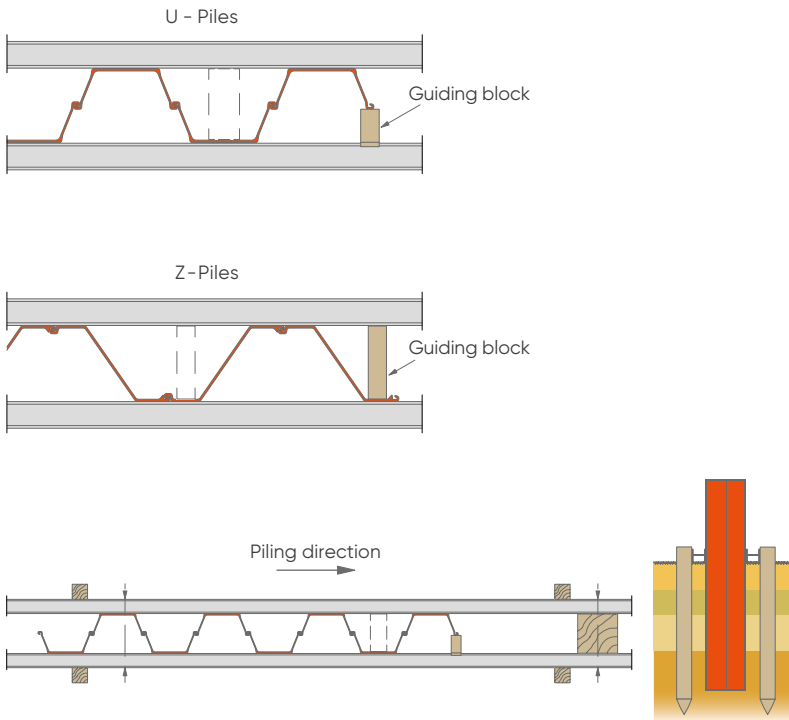

Guiding frame details

Each element to be installed should ideally be guided at two levels. Choosing the optimized distance between these two guide levels can

improve the accuracy of the guidance. For very long sheet piles, intermediate guides may be required to prevent deflection or other associated effects during driving.



Adjustable guiding frame



Example of a simple fixed guide

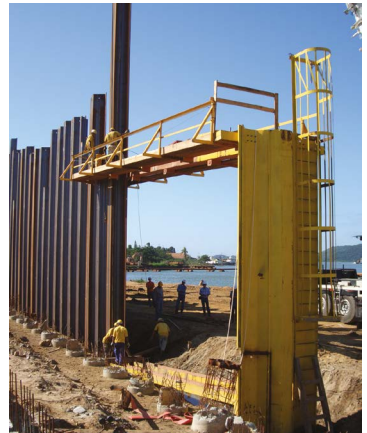

Guide frame with 2 levels



## 4.2. Leader guided piling

### 4.2.1. Piling with telescopic leader

Modern telescopic leader rigs are ideal for small and medium- sized construction sites. The units are easy to transport and ready to use within a very short preparation time. The vibratory hammer and the pile are guided on a hydraulically adjustable leader mast. It is important that the leader is always in vertical position; readjustment is easily possible by the machine operator. Impact hammers or presses can be fitted as an option. Due to the pre-tension that can be applied by the leader mast, it is possible to use relatively small high frequency vibrators.

Most machines allow quick conversion to drilling operation, so that one unit can be used to pre-drill and consecutively vibrate the piles in the correct position.



### 4.2.2. Piling with fixed leader

A rigid leader mast can generally be attached to the same carrier machines as the telescopic leader. Due to the stiffer mast design, higher loads can be taken or inclined piling can be carried out to a certain extent. The same possibility exists to apply a pre-tension force, which allows the use of a lighter vibratory hammer. The pile driver is normally installed perpendicular to the mast, allowing operation close to existing buildings.



Vertical travel leader masts normally consist of a stable boom construction and can be attached to normal crawler cranes. They allow for very large pile lengths and loads, e.g. for the driving of king piles in combined walls.

The mast allows for precise pile guidance, ensuring accurate placement in the designed position. The geometry of the equipment allows for a wide working radius. An additional simple guide frame is recommended at ground level.



Free hanging leader masts are often used for inclined pile driving, like long anchor piles. Vibratory hammers or hydraulic hammers can be mounted. Working lengths of over 60 m have already been achieved. The sheet pile can be picked up together with the vibrator, both already fixed to leader mast. The system is then moved to the pile driving position and fixed to allow for accurate piling at the given place.

If pile length demands, an adapter piece can be attached to the leader mast foot.

Short free-hanging leaders are also available on the market.

They are mostly used to re-drive already vibrated sheet piles or piles. The hammer can also be guided by so-called sheet pile legs.





### 4.3. Guiding frames

If pile installation is done free hanging without a leader, the use of a stable guiding frame with 2 levels is recommended. The distance between the upper and lower guide should be at least one third of the pile length, but not less than 3 m. The Z or U piles should fit with a small clearance of about 1cm to each side. To reduce friction between the sheet pile and the guide, plastic sheets (neoprene or similar) can be inserted or rollers can be used if piles are coated.

The pile guide should be made of strong beams and as far down as possible, generally at ground level. The guide must be secured against lateral movement by strong auxiliary beams or fixed braces. The length of the guiding frame should cover at least 6 double piles, additionally including the existing wall by approx. 1.5 m. The distance between the beams must be ensured by spacers.





Brackets made of steel can be arranged in addition. A further guide element can be placed in the direction of driving in front of the pile to be driven, at the free flange end of Z-piles or the free interlock of U-piles. This will prevent the piles from turning within the guide.

When driving in water, the upper part of the guide frame should be fixed as close as possible above the water level.

## 4.4. Combined walls

For combined wall installation, accurate placing of the king piles is most important. If a sufficiently dimensioned leader is available, a simple guide frame at the bottom or near the water surface is sufficient. If pile driving is carried out in water, a jack-up platform with sufficient load-bearing capacity should be used to work independent of tidal variation or wave actions.

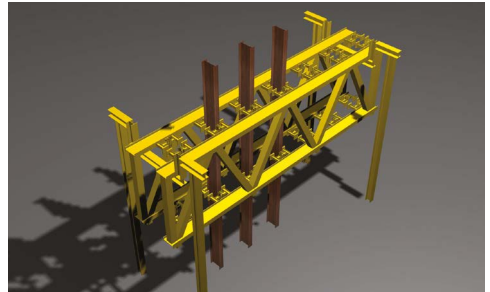

Guide frame with two levels for the HZ<sup>®</sup>-M system

Simple pontoons are not stable regarding wave actions or movements introduced by crane operation. Safe and adequate work conditions must be guaranteed. At least 6 king piles should fit into the guiding frame, with the last driven pile serving as anchor pile, to ensure correct spacing of the next piles.

The use of vertical piling guides can be considered, requiring experienced planning before construction begins.

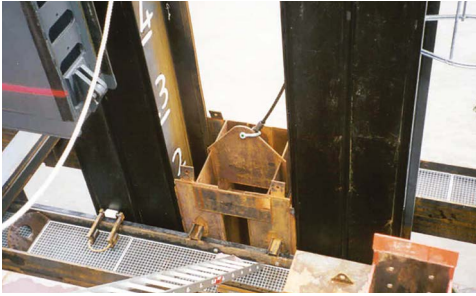

Example of a vertical guide between two HZ®-M beams



Example of a simple guide frame for tubes



Special open guide, only holding the HZ®-M beams at the rear flanges



Example of a guide frame for CAZ box piles

When installing pipes, it is important to consider that they have a tendency to rotate. Rotation can be prevented or limited with simple guides at the position of the interlock. Beams or box piles offer more safety in positioning and better resistance when driving in hard soils.

No separate guide is necessary for intermediary piles, as the already placed king piles take over this function. Z-piles are always preferable to U-piles because the rotation capacity of the middle Interlock eccentric to the system axis, provides more adaptability.

For economic reasons, the guiding frame should be designed in such a way that different profiles can be used just by adjusting the width of the frame.

#### 4.5. Circular cells with AS 500® flat profiles

To erect circular cells made of AS 500 flat piles, a guide frame is absolutely necessary. Depending on the length of the piles, two or more guiding levels are required. The outer diameter of the guide frame must be slightly smaller than the cell diameter. In practice, for a given nominal profile width of 500 mm the diameter calculation should be done with 503 mm per profile. While placing the piles around the frame, the flat sections must be

temporarily fixed to the guide until the cell is closed. Fixing can be done by welding hooks or small steel profiles to sheet pile and frame.

With the start of the actual piling sequence after closing the cell, each corresponding fixing must be released and the pile can move down, guided by the interlock of the adjacent pile.

The guide levels should be adjustable in height to allow for pulling-out during backfill operation. Auxiliary piles are normally used to provide a secure foundation for the guiding frame. A guide shall also be provided for the intermediary arcs.

For small cell diameters, it may be necessary to use factory-bent sheet piles. Depending on the pile length,  $4.0\text{--}4.5^\circ$  interlock rotation can be assumed. In addition, the single pile can be bent up to approx.  $12^\circ$ .

The stability of the guiding frame is determined by the boundary conditions of the construction site. Further information on flat profiles can be found in chapter 10.

## 4.6. Flat cells with AS 500® flat profiles

The construction of flat cells is much more difficult, as pile placing needs to be done continuously to ensure sufficient stability of the structure. Staggered panel driving is highly recommended. The details of installation must be planned specifically for the given project.



Guide frame main cell



Guide frame for intermediary arc

# 5. Installation techniques

## 5.1. General information

For any construction work, execution shall be adapted to the local site conditions. All applicable safety regulations must always be observed. Transport and installation of sheet piles must not be an exception.

The first pile must be placed in the correct design position to achieve best installation performance in accordance with the working plan and schedule. Verticality must be checked by spirit level or other suitable means. For the following piles, it must be ensured that sufficient threading length is provided to allow safe placing of the installation equipment on the pile.

This can be achieved for example by pre-excitation, which at the same time shortens the pile-driving length. The crane shall always be dimensioned with sufficient lifting height and lifting capacity to carry out all lifting operations safely.

For standard sheet pile walls, the use of double piles is the quickest and most economical method. U-shaped piles can be driven as single piles without any problems, however, a static calculation to verify the shear force transmission in the interlocks is recommended.

Driving single Z-piles is only recommended in exceptional cases, as the stiffness of the section is reduced compared to double piles. For corner constructions or for jagged-AZ® walls, installing of single Z-piles can be considered.

As intermediary piles in combined walls, uncrimped or partially crimped double piles (AZ®) or triple piles (PU®/GU®) are

recommended. This will help to compensate for any installation tolerances imposed by the already installed king piles.

For very long sheet piles, a tack welding of the middle interlock for transport may be considered for safety reasons.

## 5.2. Pitch-and-drive installation

The most common piling method is continuous piling, where each pile is picked up and immediately driven to final depth. This type of driving can be carried out in loose and medium dense soils and with short pile lengths.

There is a risk, that the leading interlock in driving direction might face deflections introduced by soil resistance. If the soil consists of dense gravel or sand, of stiff cohesive soils, or if obstacles are to be expected, then staggered or panel driving is recommended.

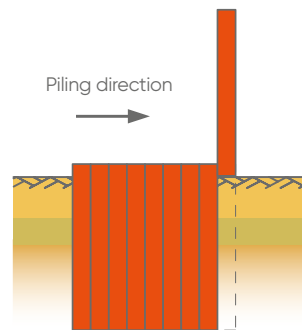

Pitch-and-drive



### 5.3. Staggered driving

The staggered installation method ensures that the sheet piles are plumb and well aligned, especially in very hard or very soft soil layers. As the piles are connected on both sides, pile stability for driving is increased and the risk of leaning forward or leaning backward of the piles is reduced (see 8.3). In addition, good control of the wall length is possible. This method should always be preferred when long piles have to be installed. Pile driving is usually done in two or three stages, with the first stage not deeper than  $0.6 \times$  the total driving depth ( $t$ ). The usual staggering can be assumed to be  $0.4 \times t - 0.35 \times t - 0.25 \times t$  for three sets.

If the soil stratification shows large differences in stiffness, the staggering should be selected in a way, that the ends of the staggering sets are lightly integrated into the hard layer.

If a pile hits an obstacle within a staggering set, the neighbouring piles can still be brought to depth and the overall piling progress does not face much slow-down in

productivity. At a later stage, an attempt can be made to pile through or remove the obstacle, using the necessary means to bring the pile to its final depth. If no further piling progress can be achieved, it can be considered to cut the pile. However, this should always be the last alternative and must be checked regarding static requirements and watertightness of the wall.

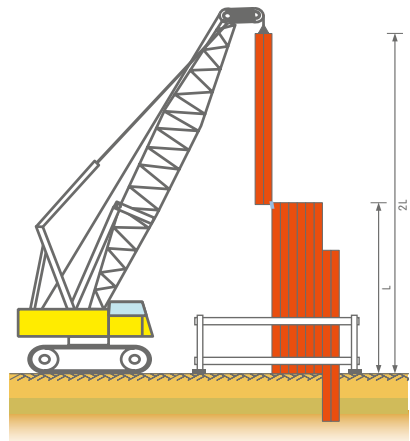

Staggered driving

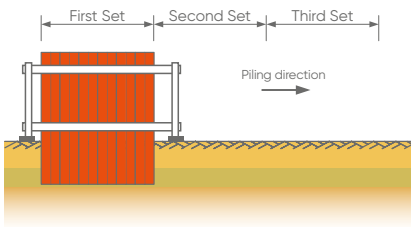

Staggered piling, step 1

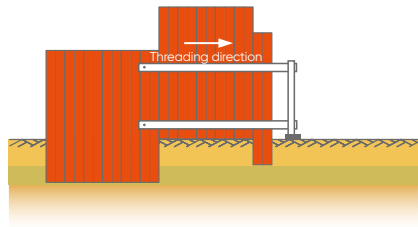

Staggered piling, step 2

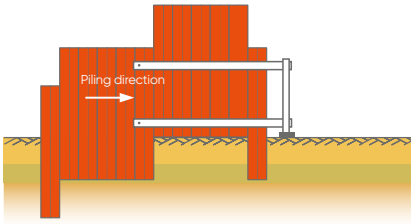

Staggered piling, step 3

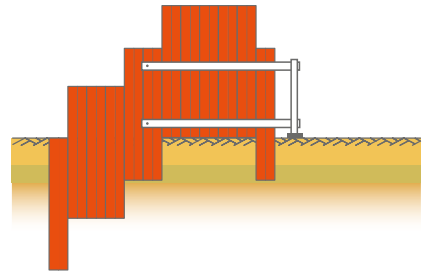

Staggered piling, step 4

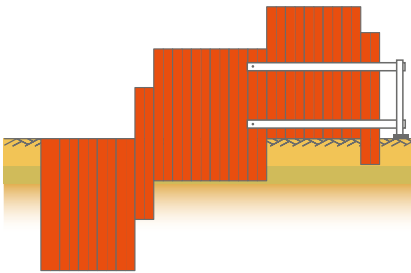

Staggered piling, next set

## 5.4. Panel driving

In the case of varying soil strata with substantially different stiffnesses, a good installation result can be achieved by using the panel driving method. The piles are securely placed in a two-level guiding frame or driven into the ground to an extent that pile stability for the free length is ensured. To penetrate the hard layers, the piles are then driven in short stages using the pilgrim-step method: first drive piles 1, 3, 5, etc. and

then piles 2, 4, etc. If a mix of very dense sand or gravel or rock is present, it may be advisable to reinforce the first-to-drive piles (1,3,5, ...) at the base and at the locks. These piles chisel and open the ground and make it easier to install the consecutive piles (2, 4, ...). Reinforcing the head of the pile can be useful for very hard driving. The plates to be welded on should have the same material thickness as the basic sheet pile.

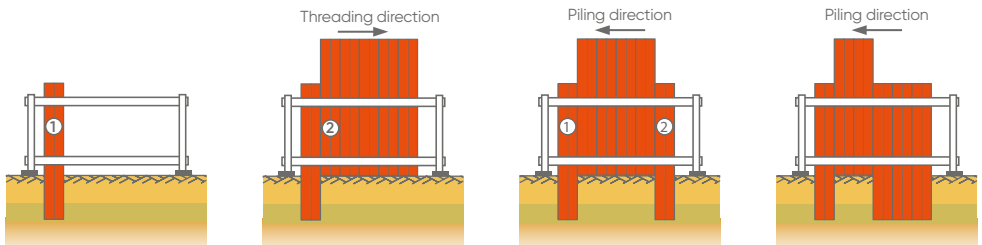

Panel driving

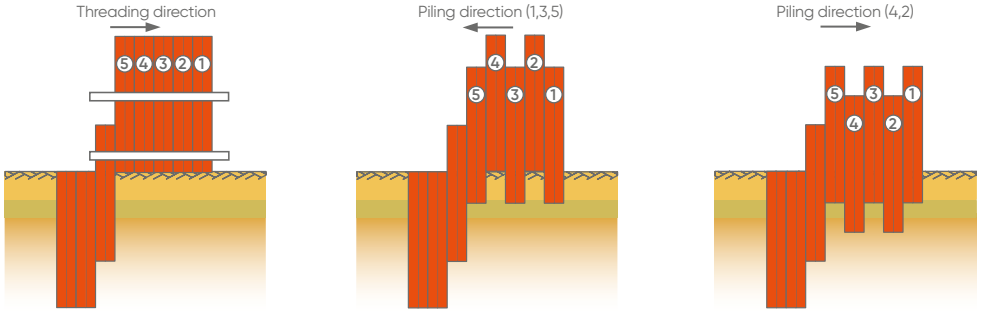

Pilgrim step piling

The reinforced piling elements (1,3,5, ...) are driven first; the others (2,4, ...) are subsequently driven to the same depth.

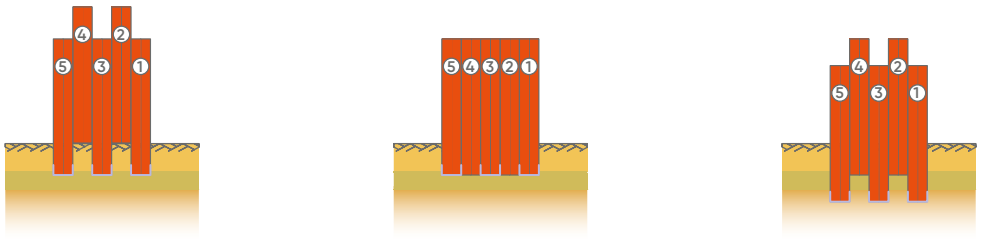

Pilgrim step piling

## 5.5. Installing combined walls

Combined sheet pile walls are formed by installing different types of sections. Long and heavy king piles with high section modulus alternate with weaker, lighter, and usually shorter intermediary piles.

King piles can be of various types: beams, pipes, or welded box piles (see chapter 9.19.). It is important that the connecting interlocks provide sufficient resistance to securely hold the infill sheets.

In any case, double Z-piles are the preferred infill sheets. With the middle interlock being located outside the center of gravity and its ability to rotate, the Z-pile offers enough rotation to sufficiently cover the allowable installation tolerances. This makes the installation between the king piles much easier. Double or triple U-piles allow only minor tolerance deviations of the king piles, as all interlocks are in the center of gravity and adaptation to the position of king piles can only be achieved by deformation. In particular, when dealing with large profile lengths or hard ground conditions, installation performance should be carefully checked.

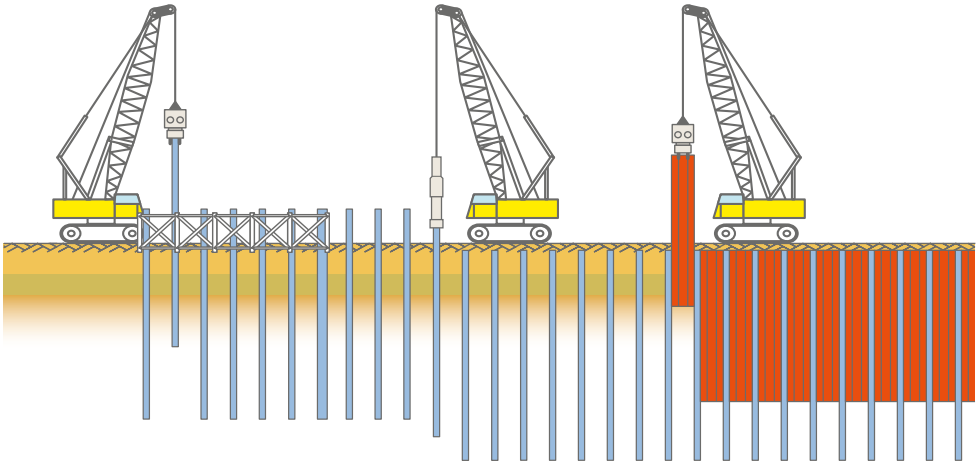

Installation scheme for combined sheet pile walls

Essential for successful pile driving is the use of a stable, heavy, sufficiently strong, and straight guiding frame, which is adapted to the length and weight of the piles. Generally, the supporting piles are driven first. Piling must be carried out with utmost care to guarantee that the piles are straight and plumb and parallel to each other and have the required spacing. The pile driving sequence shall ensure that the toe of the king pile enters compact soil evenly and over its entire circumference. This can be achieved by piling in the sequence below:

6 - 4- 2- 1- 3- 5 (pilgrim step)

or:

2 - 6- 4- 5- 3- 1

No pilgrim step is necessary for the infill sheets.

If possible, the king piles should be driven without interruption to the final depth, or at least to the upper edge of the piling guide. During driving, the alignment should be checked continuously by a theodolite. After removing the guiding frame, a final check of the pile position should be done to ensure that any deviation between the king piles is within the defined tolerances.

If any deviation is outside the previously specified or acceptable tolerances, either the intermediary pile must be adjusted, or the king piles must be pulled out and driven in again in the correct position.

If difficult pile driving conditions are anticipated, it may be necessary to consider piling aids such as pre-drilling or water jetting.

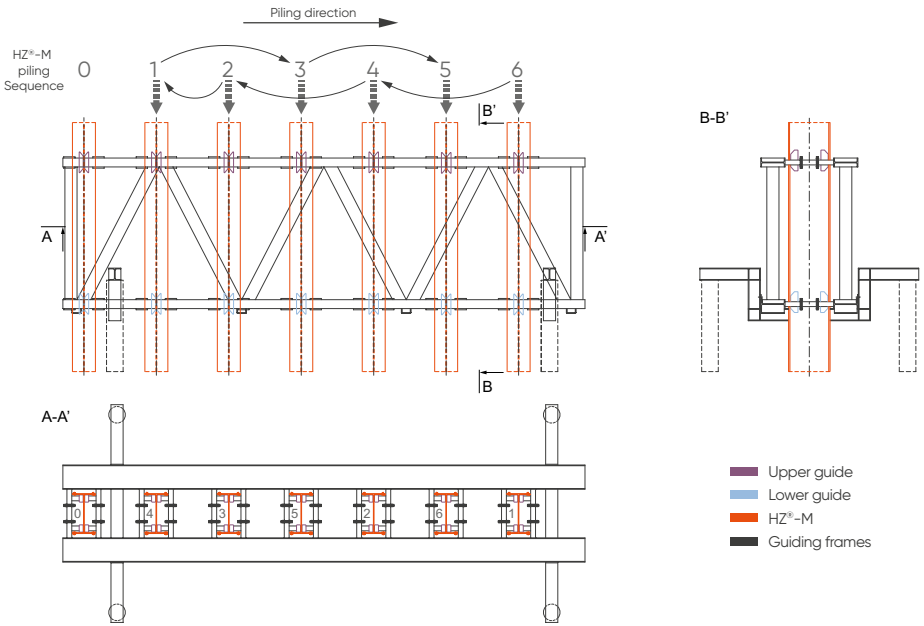

Head and toe reinforcements are possible for king piles and intermediary piles. Special cutting of the web and flange of king piles, or toe strengthening of intermediary piles according to chapter 9.12, have been used

with success. If there is any doubt about the ability of the intermediary piles to penetrate hard soil layers, pre-augering or jetting can be considered only for the intermediate piles.

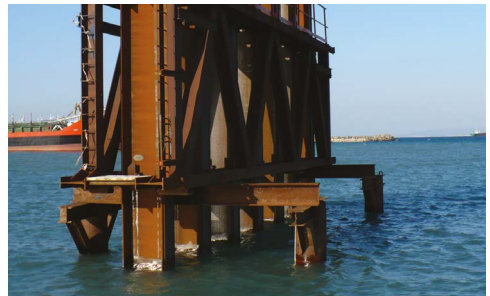

Example for a piling guide for a combined HZ<sup>®</sup>-M wall, adaptable for different king pile sizes

Continuous piling must not be used for combined walls, as the intermediary piles do not have sufficient stiffness to guide the king piles. As consequence tilting of the wall might occur.

To do an assessment of the load-bearing capacity of the king piles, it is necessary to drive the last 2 m with a hydraulic or diesel hammer. Corresponding data for the calculation can be taken from the piling protocols to be prepared (see chapter 5.9. and 9.4.).

## 5.6. "C1" and "C23" walls

In special cases, where high loads must be transferred, no tie-back or bracing is possible, or only a very low deformation of the wall is allowed it may be necessary to construct a wall using only HZ<sup>®</sup>-M king piles. Either single king piles ("C1") or double king piles ("C23") can be connected with RH or RZD/RZU interlocks. Considering manufacturing tolerances, and to facilitate installation on site, these special wall forms are connected on one side only. Pile driving is best done using the staggered driving method (chap. 5.3.) or panel driving (chap. 5.4.).

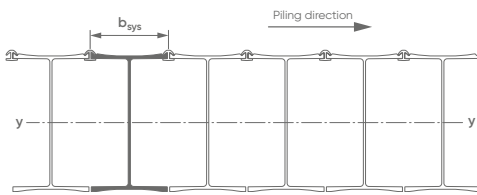

C1 - Wall

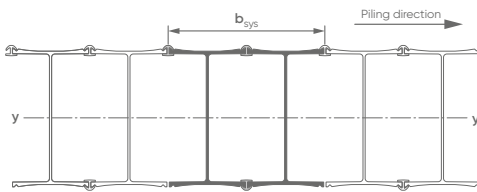

C23 - Wall



C1 - Wall with RH connection

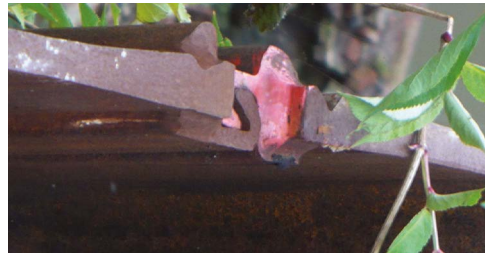

C1 - Wall with RZD-RZU connection

## 5.7. Placing in slurry walls or mixed-in-place walls

In some projects, it can be beneficial to combine the load-bearing capacity and watertightness of a sheet pile wall with the corrosion protection of the concrete. Especially in dykes or close to sensitive buildings, placing the sheet piles in a slurry wall can be a durable and economic construction solution, that can be executed with very low vibration.





Furthermore, watertight and load-bearing walls of underground garages or for safe and long-lasting containment of contaminated sites, a sheet pile wall placed in a trench is the best solution.

The slurry wall can be produced using a single-phase or two-phase system. The mixed-in-place wall (MIP wall) needs to be adapted to the local soil conditions to achieve the best installation result. The sheet piles can either be inserted by means of light vibration or just using the pressing force of the leader mast. The most suitable sealing system is Beltan (bitumen based) or Akila sealant. For contaminated sites, it is advisable to check if the sealant is appropriate for the given environment. Cut-off elements required for diaphragm wall excavation can be made on site using available sheet pile profiles or beams.



Example of a cut-off element

## 5.8. Submerged piling

Where piling work below water level is required, several methods are available for installation. If an impact hammer is used, a so-called "follower" can be used, an extension piece that is inserted between the hammer and the head of pile. The length of the follower must ensure, that the hammer always remains above the water level. The same is possible for vibratory hammers, just the clamps must be attached to the lower end of a steel beam which is firmly connected to the vibrator. It is important that the additional weight of the extension is included in the power calculation of the vibrator, to prevent underestimating the working amplitude. Extensions always require the use of a larger machine, as additional mass must be moved.

Air-powered fast-acting hammers can work under water, provided the exhaust remains above the water level. Many hydraulic vibro hammers and hydraulic hammers can work under water with minor changes, for further

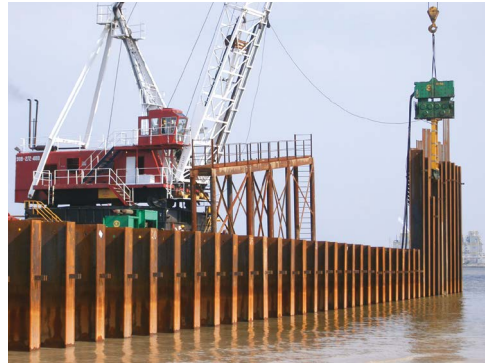

Vibro hammer with extension piece



Extension for impact hammer ("follower")

details the machine manufacturer should be consulted. It is advisable to do underwater piling using the staggered driving method (see 5.3), as this allows the sheet piles to be threaded over water. Special fabricated hammers can even use water as a substitute for hydraulic oil.

### 5.9. Pile driving protocols

A piling protocol should be established for each driven pile, recording the most important data about the driving.

Today, automated data systems are integrated in most modern pile-driving equipment, which allows to print out a documentation at the end of the working day, containing information about each pile installed. By checking the piling records, a plausibility check of the actual soil conditions can be done against the original soil investigation. In addition, if extracting piles is foreseen, preliminary extraction planning can be done (see chapter 11).

The protocol should contain information about:

- Date;
- Location;
- Piling machine;
- Driving time per depth unit (vibrating, hammering & pressing);
- Blow count per depth unit (impact hammer);
- Drop height ram weight (impact hammer);
- Hydraulic pressure (vibrator, hydraulic hammer, press);
- Remarks.

<b>Piling protocol</b>					
Construction site _____			Date _____		
Customer _____			Page _____		
Piling machine _____					
Operator _____					
Sheet pile profile _____					
Profile length _____					
Pile no.	Type	Piling-depth m	Hydr. pressure	driving time	Comments

Example of a pile driving protocol - vibratory pile driving

<b>Piling protocol</b> Construction site _____ Customer _____				Date _____ Page _____		
Piling machine _____ Operator _____ Sheet pile profile _____ Profile length _____						
Pile no.	Type	Piling depth m	Drop-Height m	Blows per 100 cm penetration	Time	Comments

Example of a pile-driving protocol – impact hammering

A printable template can be found in Appendix A.

### 5.10. Productivity assumptions

The achievable daily installation rate for sheet piles on a job site depends in particular on the following factors:

- Soil conditions
- Type and power of the piling machine;
- Length, weight and stiffness of the profile to be installed;
- Profile type;
- Experience of the piling crew;
- Working hours per day.

In soft soils, driving rates of several hundred square metres per working day have been achieved. Average values to estimate the daily production for constructing a standard sheet pile wall using the vibration method are given in the table below. For impact driving, 50% of the table values can be assumed. However, a combination of both methods is often used. Sheet piling presses are not considered here.

As a theoretical basis for a productivity assessment, the following installation rates per hour can be assumed:

Soil condition	Piling condition	Pile length		
		6 – 12 m	up to 20 m	up to 31 m
<b>loose (SPT 0-20)</b>	<b>easy</b>	4 – 5	3 – 4	2 – 3
<b>normal (SPT 20-40)</b>	<b>medium</b>	3 – 4	2 – 3	1 – 2
<b>hard (SPT &gt; 40)</b>	<b>heavy</b>	2 – 3	1 – 2	1

Average installation rate in double piles per hour, using vibratory hammer. For impact pile driving, 50% of the table values can be assumed.

For combined walls, the installation of the king piles is the ruling factor. Depending on soil conditions and profile type, installation can vary a lot. Nevertheless, with long profiles

(>28 m) and heavy piling, it should be possible to install at least 3-4 king piles per day.

Assumptions for cell construction are given in chapter 10.7.

## 6. Transport and storage

### 6.1. General information

Whenever working with sheet piles, the safety of people and material must always have absolute priority. Sufficiently dimensioned and approved equipment and suitable equipment must be used for transport and lifting. Regarding the acceptance of material on site, reference is made to EAU 2020 (Chap. 8.1.2.3).

### 6.2. Transport



Depending on the job site situation, it may be necessary to plan for special means of transport already before the start of the work. Rough terrain, very long profiles or small access roads and bridges can turn into major challenges.

### 6.3. Storage

For the correct storage of sheet piles, the recommendations of DIN EN 12063 should be observed. The maximum number of piles to be placed on top of each other is limited either by the load-bearing capacity of the soil, or the risk of tipping of the stack. In case of Z- and U-double piles, timbers (a) are to be placed in such a way, that sufficient support of the stack is ensured, and plastic deformation of the lower piles does not occur.

If multiple layers of spacing timber are installed, the timber pieces must be aligned. If piles are coated, each pile must be separated with a timber to avoid damage to the coating.

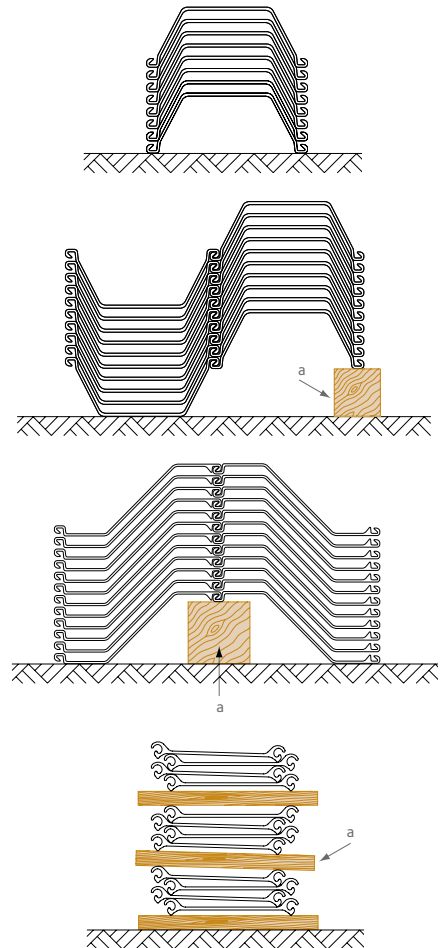

## 6.4. Shackles and lifting gear

In addition to the common standard shackles, there are specially developed safety shackles for lifting sheet piles. These shackles make it possible to release the pile attached under the crane from the ground. To connect the shackles, a hole is required on the pile head through which the shackle pin is passed. This method is fast, efficient, and safe.

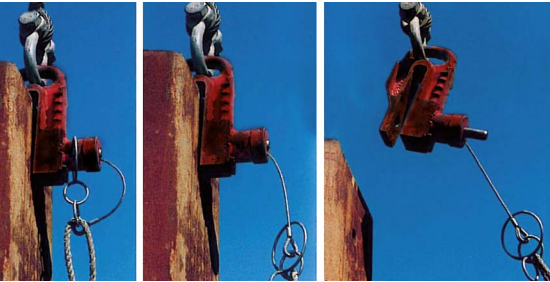
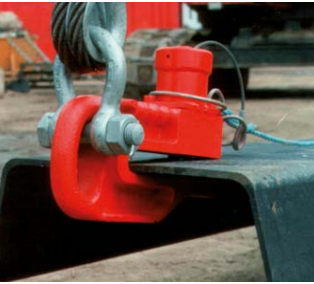

Special lifting claws are available for easy and safe lifting of horizontally stacked piles. These are simple equipment designed to grip a single pile or several stacked piles, allowing easy separation and lifting of the piles.

So-called toggle chains are mounted directly on the vibratory hammer. They can be found especially on leader-mounted vibros and allow for safe lifting and threading of the sheet pile to the clamps. Falling-down is not possible, as the profile is always secured to the equipment. The handling holes of the sheet piles should be ordered at the factory according to the size of the toggle chains, or should be adapted on site. The position of the clamps must also be considered.

The use of cut interlock pieces is not recommended, as uncontrolled material failure is possible. Lifting by means of a grab attached to an excavator should only be carried out with special equipment developed for this purpose and operated by trained personnel to avoid pile damage.

## 6.5. Threading equipments

During construction progress, it is often necessary to thread sheet piles at certain height. For reasons of work safety, a lifting platform should be employed. If this is not possible, automatic threading equipment can be used, that eliminates the need to lift personnel to the pile head to manually connect the interlock. The worker places the equipment at the bottom (1), the crane moves pile and threader along the already installed pile upwards (2) and once the top is reached, a spring mechanism pushes the threading lock into the correct position (3).

When the pile is lowered, the interlock connects automatically (4). The mechanism is available for all types of sheet piles, safe threading is thus possible also in windy conditions.

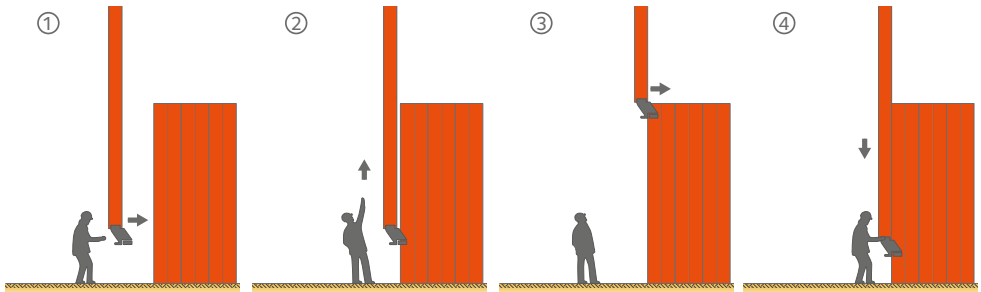

- ① Picking up the pile with safety shackle.
- ② The sheet pile threader is placed at the lower edge of the pile to be threaded approx. 1 m above ground level and fixed with a screw. The pile with the threader is placed on the side against the driven pile so that the interlocks of both piles are close to each other.
- ③ With the help of rotatable rollers, the threader is attached and the sheet pile interlocks are pressed together by a spring force. The pile to be threaded is sliding along the already placed pile. Swinging is prevented during lifting. When the threading height is reached, the pile is pressed into the threading position by the spring force. When lowering, the pile automatically threads itself into the lock of the standing pile.
- ④ After reaching the ground, the sheet pile threader is detached from both piles and removed in a few simple steps. With the safety shackle disengaged, a new working cycle begins.





## 7. Installation aids

### 7.1. Water jetting

#### 7.1.1. General information

Water jetting can be combined with all installation methods. It can significantly increase the productivity of a job site. Machine overload, deformation of the piling elements and ground vibrations can be reduced.

The jetting process is such, that a controlled waterflow is directed through one or more jetting pipes to the toe of the piling element. The water loosens the soil and helps to move loose material. Depending on the soil structure, the peak resistance and skin friction are reduced, and the interlocks are lubricated by the water flow.

The effectiveness of water jetting is limited by the type of soil, but also by the number of jetting pipes and the water pressure applied. A pile test is always recommended to determine the best fitting parameters for the given project. In general, the jetting pipes should not be too large to avoid erosion of the subsoil, followed by a possible reduction in the load-bearing capacity or unplanned settlements.

If required, a cement slurry can be injected after the water jetting to provide additional watertightness or higher load-bearing capacity of the pile. Grouting to close the gap after the piles have been pulled out is also possible through the jetting pipes.

#### 7.1.2. Low pressure jetting

The low-pressure jetting method works best in dense to very dense, non-cohesive soils and silty sands, but good installation success can also be expected in dry, uniform-grained sandy soils mixed with gravel.



Generally, water jetting is used together with vibration. Due to the reduced friction, a good installation productivity can be achieved using smaller machines. Two to four pipes of about 1" diameter are fixed firm to a double sheet pile and each is connected to a pump of about 20 bar capacity. The end of the jetting pipe should be at the same level as

the sheet pile toe. If the pipe is shorter, the flow of water to the other side of the sheet pile might be affected; if the pipe is longer, there is a risk of bending the pipe and a loss of effectiveness can occur.

It is important that the water flow starts shortly before or at the same time as the vibration. This prevents soil material penetrating the pipe or nozzle, leading to clogging.

It can be stated from long experience, that the soil characteristics are only slightly and temporarily changed during jetting (see also EN12063-2023). If vertical loads are to be transferred later, special care must be taken, and it may be considered to work without jetting for the last 1-2m.

### 7.1.3. High pressure jetting

This method is suitable for driving sheet piles in extremely stiff and cohesive soils. In areas where settlements should be avoided, high pressure jetting is favorable, as a smaller quantity of water is required than for low pressure jetting.

The soil properties remain unchanged by the jetting process; this has been proven by soil investigations after the installation of sheet piles in limestone and boulder clay as well as cretaceous clays.

For the jetting precision pipes (e.g. 30 x 5 mm) are used, the jetting pressure at the pump is in the range of 250 to 500 bar. Special nozzles in fabricated holders (round jet nozzles with 1.5 to 3.0 mm) should be used. Occasionally, flat-jet nozzles are also useful. The water is supplied by piston pumps delivering 60 to 120 l per minute per nozzle.

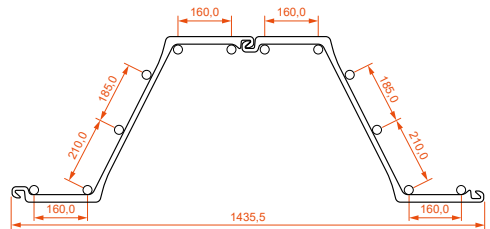

The pipes should be guided in brackets welded along the pile in such a way that they can be recovered optionally. The jetting pipes must be fixed to the sheet pile in such a way, that the nozzles are placed 5 to 10 mm away from the pile toe.

Intensive monitoring is required while carrying out the jetting work, to ensure possible adaptation to local ground conditions. The diameter of the nozzles as well as the number and arrangement of the lances must be adapted to the soil conditions.

Overall, the low pressure jetting method is simpler and more user-friendly.

## 7.2. Drilling

In hard cohesive soils, pre-drilling is a very effective installation aid. The drill diameter should be about 1/3 of the pile width. The auger must be sufficiently stiff to prevent a possible deviation in the ground.

The most effective borehole spacing should be determined empirically on site. In difficult driving conditions, the spacing may be reduced to overlapping boreholes. The soil loosening and displacement reduces the penetration resistance of the sheet piles.

If larger hole diameters are required, filling with suitable material might be considered. Even soils with hard rock layers or rock can be well prepared for pile driving by this method. In individual cases, full soil replacement can be considered.

The drilling is usually done in the area of the locks.



Pre-drilling for intermediary piles of a combined HZ<sup>®</sup>-M wall

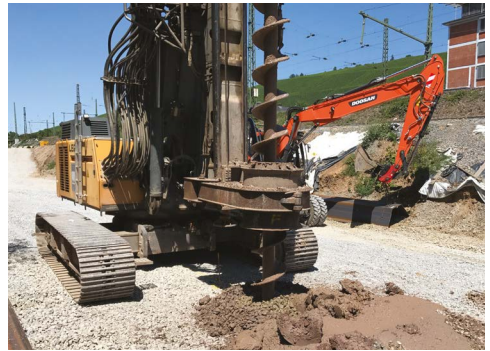

Example of CFA in use on site

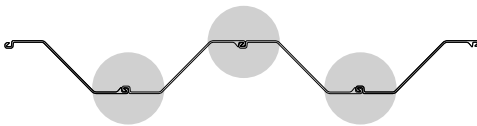

Example of a drilling scheme for Z-piles

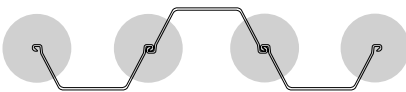

Example of a drilling scheme for U-piles

## 7.3. Cutting

If the sheet piles are to be installed in rocky soils, opening a trench using a cutter can be an option. Cutting machines can be used very economically in both situations, dry and submerged. Large working depths can be achieved by selecting an appropriate carrier machine. Cutters are available on the market as standard attachments.



## 7.4. Blasting

### 7.4.1. General information

The blasting method can be used in soil types that are considered difficult or unsuitable for driving sheet piles. The influences on neighbouring structures must be considered during planning.

### 7.4.2. Loosening blasting

A series of opposite boreholes in the sheet pile line are charged with explosives in a way, that after blasting a V-shaped area is created in which the rock is more or less destroyed. The resulting "rough gravel soil" can be classified as difficult piling conditions. It is necessary to choose a sufficiently stiff profile to avoid deformation of the sheet piles in the ground.

Reinforcement of the pile toe according to chapter 9.12. may be appropriate.

### 7.4.3. Shock blasting

In this method, boreholes are drilled to the target depth in a distance of 0.6 m to 1.2 m. The borehole spacing and charge size must be adapted to the strength of the rock. Two to eight neighbouring boreholes are always fired simultaneously. The rock is loosened by the impacting pressure waves without being blown away. In the areas of the explosive charges, limited straight loose rock zones with a width of 0.4 to 0.8 m are created.



To make this method most effective, the steel sheet piles should be installed in the loosened zone as soon as possible after blasting. Toe reinforcements are also useful here.



## 7.5. Further practical installation hints

Based on construction experience, some simple measures can make sheet pile driving considerably easier. A bolt inserted in the leading interlock in the direction of driving prevents soil particles entering and reduces interlock friction. In addition, if the interlock is filled with Beltan® Plus, grease or construction foam, the positive effect on piling is even greater.

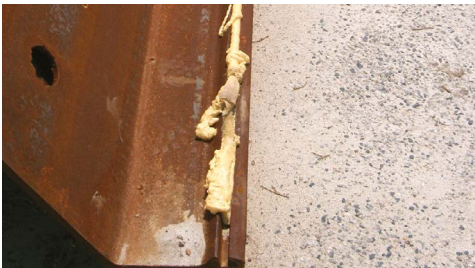

## Interlock protection

The installation of intermediary piles of combined HZ®-M walls can be facilitated by adding some interlock protection. A square steel piece can be welded at the end of the RZU and RZD lock on the king pile, to break up hard soil and reduce the resistance for the following intermediary pile.



Interlock protection



Flat steel at the end of the pile

By attaching a piece of flat steel to the end of the threading lock, lock damage can be prevented during piling, as the interlock cannot move out of its position.

To clean the inside of the connecting interlock from sand, stones or residues of diaphragm wall slurry, interlock sections with an inclined cut can be used, or the pile to be installed is directly prepared accordingly. The material trapped in the Larssen lock is thus pressed outwards.

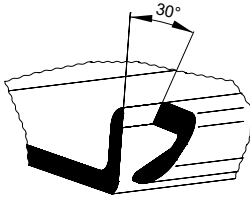

Z-pile, unstraight interlock

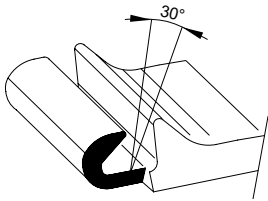

Z-pile, straight interlock

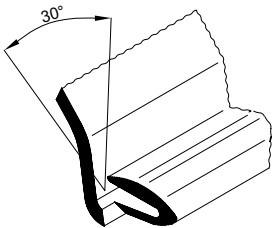

U-pile

The same preparation of sheet pile interlocks is foreseen when using the ROXAN® Plus or Akila® sealing systems.

## “Cutter piles”

If obstacles are to be expected in the construction area, like old wooden foundation piles, tree trunks, or even thin metal objects, the obstacle can be cut or hammered through with the help of a “cutting pile”. Although there is no guarantee of success.

Where driving conditions are not readily predictable, it can be an option to drive uncrimped double piles as double piles first and later switch to single pile driving, if the installation progress is insufficient. This reduces the weight to be vibrated and a deeper penetration can be achieved. It should be noted that where U-piles are used, it is necessary to check wall stability regarding shear force transmission.

During the installation process of uncrimped profiles, relative displacements of the double piles must be prevented by constructive measures (normally a tack weld at the head).







## 8. Pile driving accuracy

### 8.1. Installation tolerances

The pile driving plan indicates the correct position and orientation of the piles. Any deviation can result from delivery tolerances, the pile driving method and the soil conditions. The following installation tolerances can be assumed as general requirements for the construction of a plumb and straight standard sheet pile wall:

a) Deviation from the wall alignment at the top of pile		± 50 mm
b) Deviation at		
Pile top		± 20 mm
Pile toe		± 120 mm
c) Deviation in verticality:	with Staggered driving	with continuous pile driving
Rectangular to the wall in % of the driving depth	± 1%	± 1%
In direction of the wall (forward and backward leaning)	± 1%	± 0,5%

Tighter or looser tolerances can be agreed depending on the structure and project. Tighter tolerance values apply in particular to the king piles of combined walls where the serviceability of the intermediary piles is not affected. Permissible rotation and leaning are to be agreed between the project partners, whilst also considering technical feasibility.

Further information on tolerances of combined walls can be found in ArcelorMittal's HZ®-M catalogue and in the recommendations of the Committee for Water Structures (EAU).

### 8.2. Control of wall length

By changing the height of the piling elements used, the profile width can be affected.

The effect is particularly strong in case of double-Z-piles, as the position of the centre interlock allows a certain rotation capability. The larger the manufacturer-specific rotation angle, the higher the possible variation in wall length. From a technical point of view, a significant reduction of the section modulus

can occur if the pile guiding is insufficient. By controlling and limiting the free space in the guiding frame, for example by inserting wooden blocks, the pile can be kept close to the target position. Blocks in the inner Z-pile can reduce, blocks in the back of the Z-pile increase the profile width. With multiple repetitions, the wall length can be corrected to the required extent. Lashes welded in

the lower part of the pile in the theoretical nominal position can improve the accuracy of the profile position, and also reduce the installation resistance.

For U-piles, no major deviations are to be expected, as all locks are in the middle of the wall. If theoretical wall dimensions must be accurately maintained, special fabricated piles may be necessary.

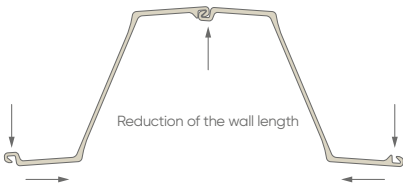
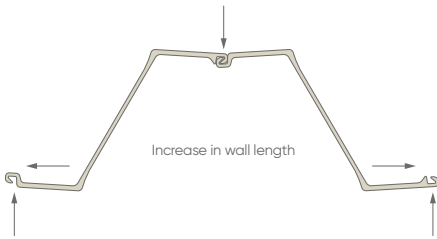

### 8.3. Leaning and verticality

Leaning of piles rectangular to the wall axis can be avoided by using leader machine or a sufficiently stiff dimensioned piling guide. If the piles nevertheless start deviating in the perpendicular direction, they should be extracted and repositioned using more suitable piling methods, for example staggered pile driving.

Leaning means a deviation of the piles in the direction of the wall axis ("leaning forward") or in the opposite direction ("leaning backward"). It is a phenomenon that has been known for a long time in sheet pile driving. Leaning forward occurs mainly in soft soils and can be explained by the fact that there is more friction acting in the threading interlock than there is resistance in the soil at the free end of the sheet pile. The wall "falls" forward. As a counter measure, staggered or panel driving can be applied. An attempt can be made to correct the inclined position by pulling the cable in the opposite direction.

If a leader machine is used, it is possible to counteract the leaning by placing the vibrator eccentric on the pile and try to correct the direction of the pile. In the worst case, a special pile must be used. Welding a small plate under the leading interlock might also help.

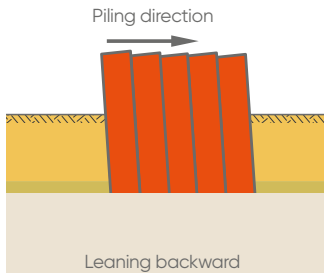
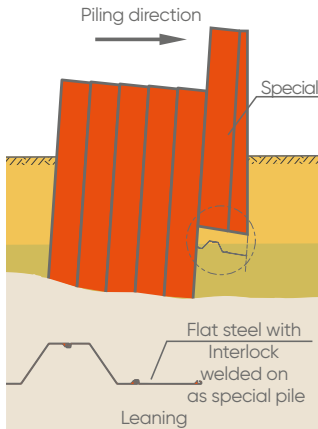

Leaning backward is mainly found in hard soils. Here the free end of the pile must at first open the soil, whereas in the threading interlock the pile can move rather easy and penetrate the already disturbed soil.

Countermeasures are basically the same as with leaning forward, except that a force must be applied in the other direction. If double U-piles are to be installed and the piles differ slightly in length, the longer part of the double pile can be installed in the leaning direction just by turning the pile.

Pre-deformation of the web is not recommended, as there is a high risk of the pile being pushed out of the wall alignment.

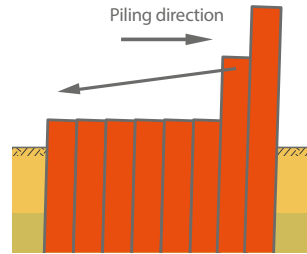

Pulling back the wall with rope

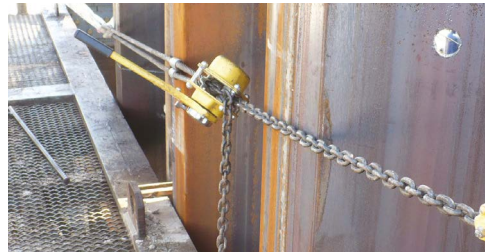

Correction by chain pull



Welded lash to fix the profile in the intended width

Possible corrective measures in case of piles leaning in the direction of the wall axis.

## 8.4. Drawing down

When piling in soft soils, especially with additional inclination of the piles, the interlock friction can become higher than the penetration resistance and cause the neighbouring piles to be pulled down. When placing piles in a slurry trench, the same phenomenon can occur. In such case, the affected pile can always be extended by welding, if pulling to the correct height is not possible.



To prevent already driven piles from being pulled down, several piles can be attached to a beam or several sheet pile interlocks can be firmly connected by tack welding. As a further precaution against pulling down, a bolt can be inserted into the leading interlock prior to driving to prevent soil entering and resulting in higher interlock friction.

Alternatively, a temporary clamping equipment can be used, which prevents the neighbouring pile from being pulled down. Blocking the piles with a bolt inserted through the handling hole also helps in most cases.

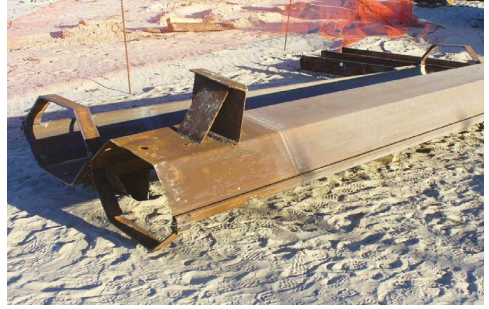

Holding equipment for sheet piles placed in a trench

## 8.5. Measurements

Before and during piling, the following points should be observed continuously:

- Position of the piles in the guiding frame
- Verticality of pile, measured in 2 axes
- Penetration velocity of pile
- Condition of the pile head
- appearance of smoke, which could indicate local overheating.

If pile-driving deviations of any kind occur, countermeasures should be taken immediately.

For the king piles of combined walls, the measurement method described below can be used.



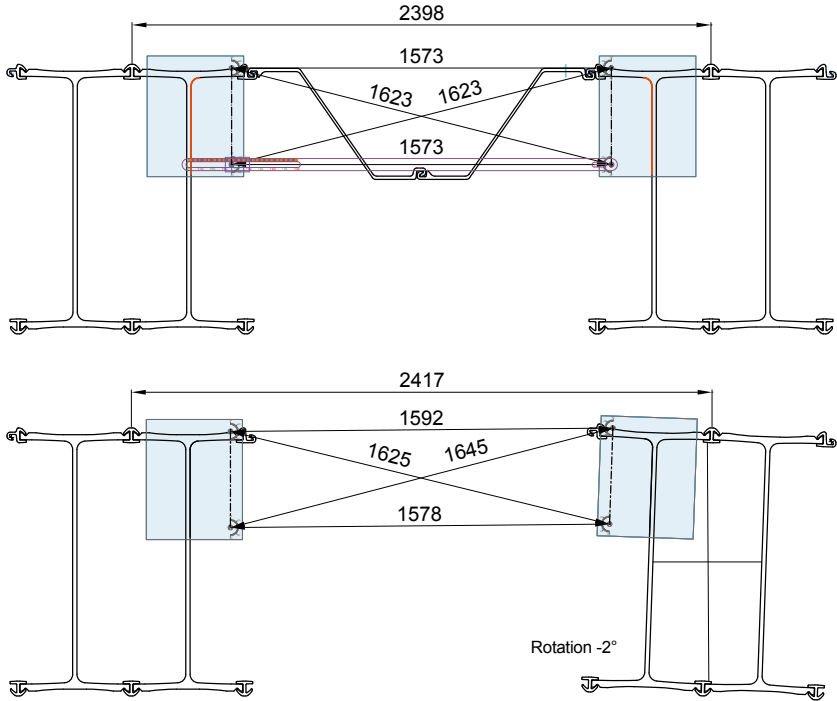

Measurement example

The actual inclination of an installed sheet pile wall can be determined with high accuracy using inclinometers. The inclinometer pipes can be installed in the factory or on site.

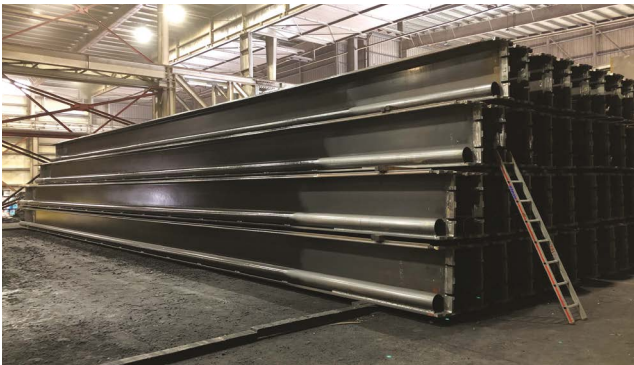

Factory-mounted inclinometer pipes; HZ<sup>®</sup>-M beams with toe reinforcements and inclinometer pipes





## 9. Special technical aspects

### 9.1. Pile driving Tests

Pile driving tests are particularly necessary when soil conditions are difficult to assess from a pile driving point of view. The aim of the test is to find the most suitable sheet pile section and the appropriate driving equipment. Furthermore, it can be estimated whether the calculated required driving depth or the pile load capacity can be achieved. If possible, the testing should be carried out in or near the planned piling area. The number and type of piles as well as the location of the driving test depend on the type and size of the construction project and the expected irregularities of the subsoil.



Piling tests must be carried out with utmost care. The pile and the piling machine are to be monitored constantly, and detailed pile driving protocols done. By excavating or extracting the piles at a later stage, an accurate judgement can be made about the behavior of the piles.

Vibration measurements can provide information on whether problems are to be expected on neighbouring buildings during the construction period.

### 9.2. Working with limited headroom

When piling is carried out under bridges or within existing structures, insufficient working height between the surface and the superstructure is often encountered. By splicing short pile sections together, any required pile length can be achieved. This method is time-consuming and expensive due to the welding under the piling machine, which is why it is only used in exceptional cases.

One possible method is to thread the piles away from the bridge and hang them in a frame attached to the bridge superstructure. The bolts required for fixing allow the pile panel to be gradually pulled under the bridge. For further height clearance, a pre-excavated trench can provide additional space. When all piles are threaded and in place, they only need to be driven down.

Appropriately modified piling equipment is available or can be adapted for the purpose.

Piling is most effectively done with fast-acting hammers or vibratory hammers. In some cases, a small hammer is used first until enough space is free for a stronger hammer.

If a light hammer cannot be placed on the pile, driving is possible with a so-called "backpack" hammer, a device that holds the hammer while hanging on the pile. The special guide transmits the hammer force to the sheet pile.

If the ground conditions permit, it is also possible to use compact excavator-mounted vibrators with side-grip clamps.



Another simple method is modified panel installation, which is shown in the following drawing. When threading the pile on the first panel, the interlock finger is burnt off at the top half of the pile along the required length.

The next pile can be hooked-in laterally (a-a). The piles now have the usual interlock guide in the bottom (c-c), the upper interlock guide is achieved by subsequently welding on a flat steel strip before driving (b-b).

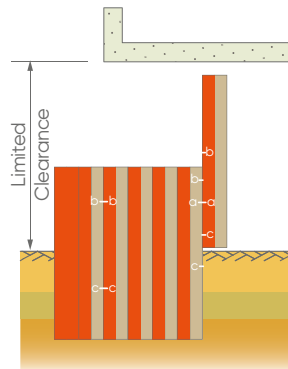
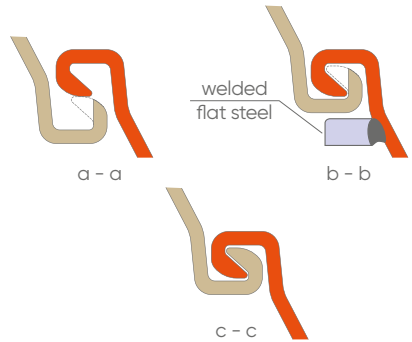
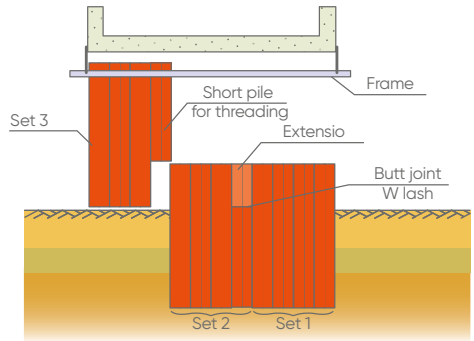

Special panel driving in restricted height situation

### 9.3. On-site threading of multiple piles

To optimize transport or as required by other site conditions, it may be useful to thread single or double piles together into multiple panels at the construction site, for example to install piles with a 4-cylinder press (see chapter 3.4.2.). The profiles must be laid out on a flat surface for this purpose. Preferably, wood is placed under the piles to reduce friction and allow sliding. The threading interlocks are placed in the correct position and then pulled or pushed into each other with a winch, wheel loader or forklift. Delivered loose corner profiles (except C9) can be assembled in the same way.



### 9.4. Vertical load-bearing capacity

The load-bearing capacity of sheet piles in regard to vertical loading is often underestimated. For the design of transferring vertical loads from the superstructure into the sheet pile head, ArcelorMittal has obtained a General Design Approval Z-15.6-235 from German construction authorities. For planning and calculation, ArcelorMittal offers a brochure on "Knife edge support" and an associated calculation program.

For the transfer of vertical loads from the sheet pile wall into the soil, reference is made to the calculation principles of EAU 2020 (8.2.5) and the "EA-Pfähle". To verify the actual load bearing capacity, it is in any case recommended to carry out a load test. If this shows that the pile length is insufficient, the sheet piles can easily be increased by welding and driving deeper.

Conclusions about the load-bearing capacity can be drawn after completing the driving works where the required penetration resistance has been achieved and the hammer performance corresponds to the expected soil conditions and the pile profile. The rule is: "A hammer-driven pile is a tested pile".

The load-bearing capacity of a hammer-driven pile can be estimated using different pile-driving formulas.

For vibrated piles, a calculation prediction of the vertical bearing capacity is currently not possible due to too many indeterminable variables. Vibrated piles must either be tested in-situ or driven by impact hammer over the last 2-3 m. It is important to check the penetration in mm during the last 10 strokes to be able to determine an average value per stroke.

A general rule is, the pile bearing capacity increases further a few weeks after installation. As a rule of thumb, the following can be assumed:

- for non-cohesive soils 5-20% increase
- for cohesive soils up to 60% increase

The increase depends on the soil type, grain shape, grain distribution, soil density, pile type and material of the pile.

## Piling formula according to Stern

The load-bearing capacity can be calculated in a simplified way with the penetration resistance for impact-driving. The penetration resistance ( $W$ ) can be calculated using the formula according to Stern:

$$W = \frac{F \cdot E}{L} \cdot \left[ -S + \sqrt{S^2 + \frac{2 \cdot R \cdot L \cdot H}{F \cdot E} \cdot \frac{R + Q \cdot k^2}{R + Q}} \right]$$

Where:

- $W$  = ultimate bearing capacity of the pile (without safety) in kN
- $F$  = cross-sectional area of driven pile in  $m^2$
- $L$  = Length of the pile in m
- $Q$  = Total weight of pile cap and pile material in N
- $H$  = Drop height of impact hammer in m
- $S$  = Average penetration of the pile per stroke in the last heat (10 strokes) in mm
- $E$  = modulus of elasticity of the pile material in  $N/mm^2$  ( $E_{\text{steel}}$ : 210.000)
- $R$  = impact weight in N
- $k$  = spring factor 0.25-0.8 (on average 0.65)

For very long piles (> 30 m) it is advisable to estimate the bearing capacity with the help of the shock wave equation. Further possibilities are offered by the pile driving formulas of Delmag, Hiley, Redtenbacher or Weisbach.



Example of a load test for a sheet pile wall

It should be noted that all pile-driving formulas only provide approximate results. To include the previously described influences and to obtain exact values for the load-bearing capacity, load testing must be carried out.

## 9.5. Noise protection

The development and propagation of noise depends on the driving method used, the equipment technology and the type of sheet pile.

Diesel, hydraulic and air hammers produce an intermittent impulse noise, even at an increased impact rate. When piling with vibrators, a continuous sound level with fluctuations is perceptible. When pressing machines are used, the noise produced is uniform and comes mainly from the engine of the base carrier.

Impact noise is usually less acceptable than a steady noise. However, other characteristics of the sound source play an important role in assessing the acceptability of the noise, such as the proximity and the use of the neighbouring buildings. In addition, other construction noises can be perceived as very disturbing, e.g. squeaking roller bearings, site traffic, etc. The duration of sheet piling works is usually relatively short compared to the overall construction period.

Pile driving is often limited to certain times of the day. Here, the short-term effect of the pile-driving cycles must be considered, as it has an influence on the determination of the overall limit values.





Sound insulation measures for hammer (up) and vibration bear (down)

There are various ways to reduce the noise level. It can either be reduced directly at the source, for example by using specially adapted sound insulation systems for hammer or vibrator. If this is not possible, a temporary shielding can be used. Here, specific construction site solutions often lead to the desired result.

When selecting the installation tool, the quietest equipment can be chosen based on the manufacturer's specifications. Regarding the clamps of vibratory hammers, care should be taken to ensure that the friction surfaces show only little wear.

Finally, the choice of profile to be installed and the respective delivery form has a noticeable influence on the noise distribution during pile driving. When using single piles, the noise development will be lower as for crimped or welded double piles.

The use of a stiffer pile will also have a positive effect on reducing the noise level in the surrounding area.

The following table shows typical values for the intensity of noise in different areas of life for comparison:

Loud Factory/Workshop	90 dB (A)
Lively street	85 dB (A)
Radio at full volume	70 dB (A)
Normal speech	55/63 dB (A)
Residential area	35 dB (A)

The characteristic noise levels for the various pile drivers are listed below:

Impact hammer	90 ~ 115 dB (A)
Fast-acting hammer	85 ~ 110 dB (A)
Vibratory hammer	70 ~ 90 dB (A)
Pressing machine	60 ~ 75 dB (A)
Measurements in a distance of 7 m	

The following table contains examples of typical sound levels for civil engineering works:

Ramming hammer	110 dB (A)
Excavator	100 dB (A)
Compressed air demolition hammer without sound insulation	90 dB (A)
Compressor	85 dB (A)
Measurements at a distance of 7 m	

The randomly chosen distance of 7 m between machine and measuring point is another important factor. All noise is reducing exponentially by increasing distance. The further from the origin the sound waves are transmitted through the air the weaker they become. The damping factor corresponds approximately to a reduction of 6 dB (A) for each doubling of the distance from the sound source. This is shown graphically in the figure below:

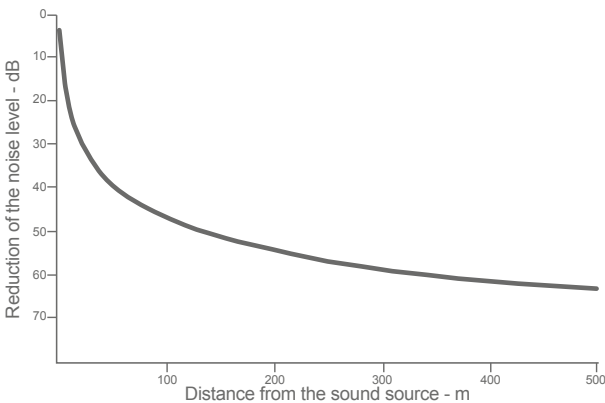

Noise level as a function of distance

The use of pile-driving aids, such as water jetting or pre-drilling, can facilitate penetration, reduce the noise level and shorten the pile driving time. Further recommendations are given in DIN EN 12063-2023.

## 9.6. Vibrations

### 9.6.1. General information

When driving a sheet pile, some of the driving energy is transferred to the adjacent ground and may be felt there on the surface in form of vibrations. These vibrations can be disturbing to the occupants of surrounding buildings and cause concern that property may be damaged. A risk assessment is advisable prior to the start of the construction work, and the preservation of evidence of existing building damage is recommended in any case. Based on existing data about the type and length of the piles, the type of hammer used and the energy applied, as well as the respective soil conditions, an initial analysis on structural vibration can be carried out. Important is the classification of the sensitivity of neighbouring structures to vibrations and a decision about appropriate measures or refusal criteria of the pile driving works. DIN 4150 Part 3 contains guideline

values for vibration effects, nevertheless the respective condition of the building and the soil must be taken into account. The building, for example, may already face some tension, introduced by different settlements uneven loading, so that a small dynamic stress can be sufficient to trigger damage. The latest version of EN 12063-2023 will contain a chapter on vibrations associated with pile driving.

### 9.6.2. Measuring systems

Numerous systems exist today, that allow accurate and simple vibration measurements during pile driving. The measuring system generally consists of a measuring device (for example a

geophone), which generates electrical signals proportional to the vertical and horizontal vibrations, and a system for displaying the signals. An alert system can be integrated which informs the equipment operator or site supervisor via optical or acoustic signals when unacceptable vibration levels are reached.

### 9.6.3. Vibration assessment on humans

An average threshold value for the perception of vibrations by humans is around 0.1 to 0.5 mm/s. In general, perceived vibrations are overestimated by humans. A simple indication of human sensitivity to vibrations is provided by the Rieher-Meister diagram.

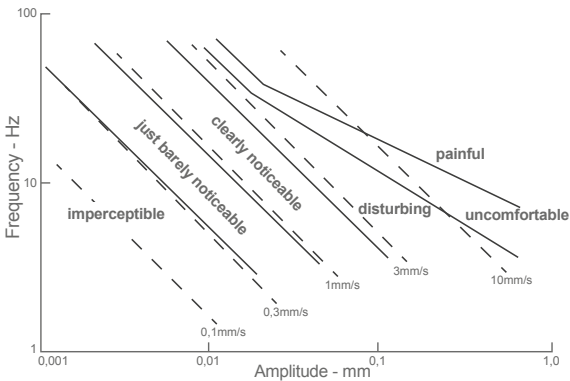

Rieher Meister diagram

### 9.6.4. Vibration assessment on buildings

The reaction of a structure to ground shaking can be determined either by dynamic analysis or by empirical estimation. Guidance can be found in European standards and in special publications. In any case, measurement during construction is the best way to correlate the real vibrations to the limit values of DIN 4150, Part 3 and EN 12063-2023.

### 9.6.5. Recommendations for vibration reduction

The parameters that can be influenced on the construction site are mainly the choice of piling equipment, the mode of operation and the control of the energy used. Impact hammers can be regulated by varying the drop height and impact piston weight. The use of bigger weights at low drop heights offers a vibration-reducing effect.

Modern vibration technology allows piling within very short distances from existing buildings. In general, high-frequency vibrators with adjustable eccentric moment cause only very moderate vibrations, as the resonance frequency of soil and building are not passed through.

Furthermore, machines with additionally variable hydraulic flow are available on the market, which hardly cause any vibrations around the machine.

In sensitive areas such as old dykes, the sheet pile wall can thus be installed quickly and effectively.

Working with hydraulic presses is almost completely vibration-free, although the achievable piling depth might be limited.

The recently developed resonance method (chapter 3.5.) works in such a high frequency range that no vibrations of noticeable magnitude occur either.

Installation aids can be combined with all of the above-mentioned piling systems and will always lead to successful pile driving.

Placing the sheet pile wall in diaphragm walls or mixed-in-place walls can also be used as a low- vibration driving method (see chapter 5.7.).

## 9.7. Declutching detectors

ArcelorMittal offers the DIXERAN declutching detector system for checking the interlock integrity down in the ground, where the pile is not accessible. Dixeran can be installed on site with little effort, making pile checking easy. The exact product description is available as a special brochure.

The number of detectors to be installed is determined before construction begins and should be adapted to the complexity of the construction site.



Dixeran detector



Connecting cable



Control box

## 9.8. "Jagged Walls"

Jagged walls are sheet pile walls in which the Z- or U-profile is arranged in a special geometry. In the Jagged U-wall, double profiles are rotated by 45° to the normal wall axis and connected with an Omega profile. In this way, a very stiff wall with a large section modulus is obtained, which does not need any anchoring or bracing. If anchoring is also necessary, the connecting construction is more complex. The advantage of the system is that standard profiles can be used and reuse is possible after the initial work is finished. A combined wall as an alternative is much more difficult to construct. Piling is done best with a flexible leader mast, as the profiles must be turned in the direction of installation in each case. A simple guide

on the ground level facilitates the exact positioning of the profiles and ensures that the correct wall geometry is maintained to prevent loss of section modulus due to piling deviations.

A jagged wall made of Z-profiles is mostly used as a pure cut-off wall, as it can hardly take over a static function. The solution is interesting because it offers a low weight per unit area and a low overall construction height.

As driving single Z-piles is rather difficult, soil investigation should be done very accurately and pile length chosen accordingly.



Jagged U-Wall



Jagged Z-Wall

## 9.9. Inclined piling

The most common use of inclined piles is as anchor piles for heavy quay walls. In rare cases, inclined sheet pile walls or combined walls are designed for architectural reasons. The difficulty is always the connection to vertical components such as wing walls. If in addition curved piling is foreseen, the sheet pile wall is additionally loaded and special care is required during installation. The shorter the piles, the easier the installation.



Inclined piles are working either on skin friction or they are designed as grouted piles (MV-piles).

Friction piles are usually longer, but grouted piles can carry more load over a shorter distance. For both types of piles, a load test must be carried out to determine the actual load-bearing capacity and to confirm the assumptions of the static calculation. For pure skin friction piles, a possible extension is easy to do by welding.



The installation starts by using a vibratory hammer. Subsequent piling to final depth is best done with a hydraulic hammer, as the least energy loss is to be expected here. Always check the manufacturer's instructions on the maximum permitted working inclination.

Either an inclined or suspended leader mast is used as a driving guide for piles; an adapted pile guide should be used for inclined standard sheet pile walls.

### 9.10. Special piles

Adapting the theoretical sheet pile geometry to the actual site conditions is often necessary. It is possible to order special piles according to the theoretical plan before construction work begins. Nevertheless, it should always be measured on site if the pile geometry fits or if an on-site adaption might be needed. Shortening or widening U- or Z-piles is easy to perform. A special brochure on welding steel sheet piles is available from ArcelorMittal.

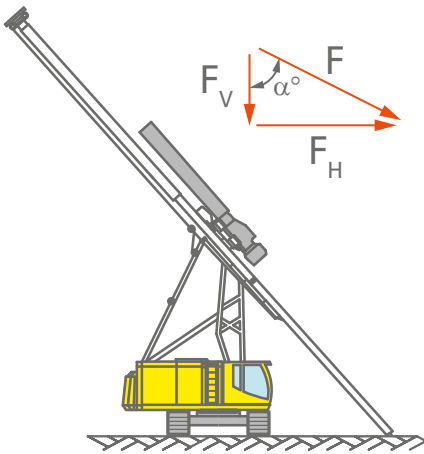

**Propulsive force**

$$F_V = F \cdot \cos(\alpha)$$

**Support force**

$$F_H = F \cdot \sin(\alpha)$$

Force distribution at an inclined leader mast

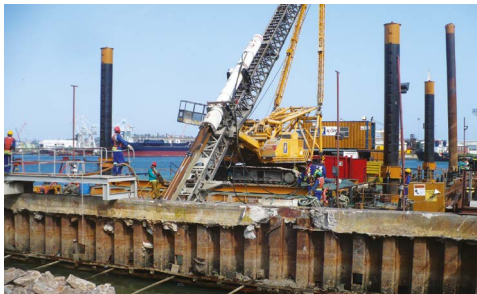
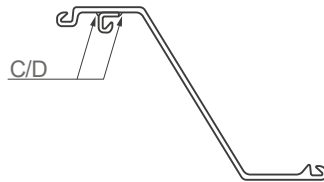
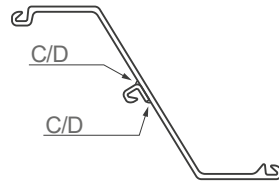
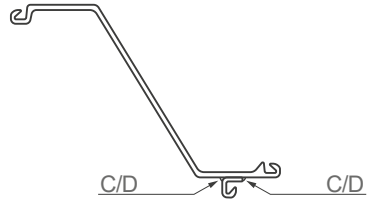

Example of C9 assembly on an AZ profile in different positions

Corners of various kinds are often needed in sheet pile construction. ArcelorMittal offers a wide range of hot rolled sections, that can be welded in any specified position according to the actual plan before installation. The C9, C14, Delta13 and Omega18 corner profiles can be supplied loose, loosely threaded or factory welded. The C9 lock offers the greatest flexibility, as it can be fitted in all possible positions and angles.

Installation is generally done with the corner welded to the sheet pile, forming a fabricated special pile. The installation of loose corner profiles is not recommended due to the lack of stiffness and no suitable clamp attaching points.

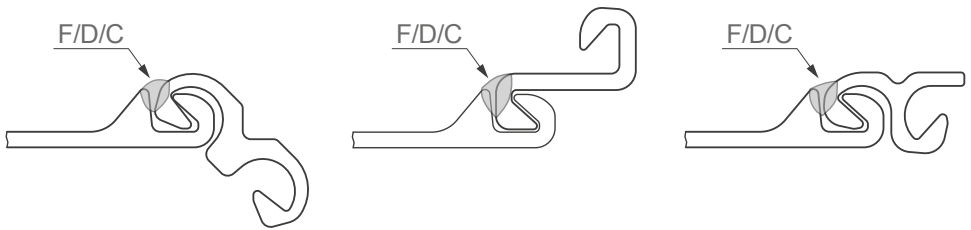

For all corner sections the following welding configurations are recommended:

- F Tack weld at the head, 100 mm, minimum weld thickness 6 mm
- D Staggered weld 100 mm (3x/meter), additional 200 mm at head and toe, minimum weld thickness 6 mm
- C Continuous weld, minimum weld thickness 6 mm

Corner section welding configuration according to factory recommendation for C14, Delta13 and Omega18, depending on site conditions or static requirements

If necessary, sheet piles can be widened or narrowed. Welded plates should have the same thickness as the basic sheet pile material. Attention must be paid to changing driving behavior and tolerance dimensions!



Widened pile

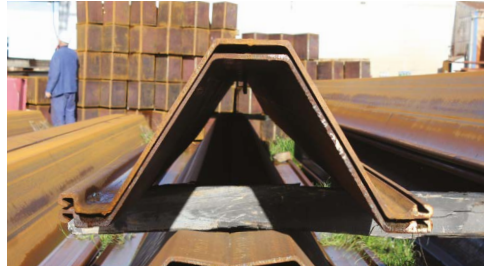

Narrowed pile

Special spring piles can form a flexible solution if the geometry of the existing wall requires it.

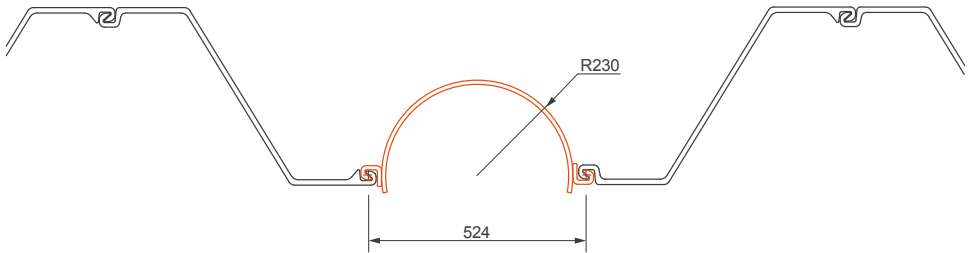

Example of a spring pile



Example of an armoured pile

To secure the sheet pile wall against ship impact, the sheet piles can be provided with armouring made of specially adapted plates. The armour plates are generally fitted before installation, but they can also be fitted subsequently.

Recommendations on the design of impact armour can be found in chapter 7.2.4. of the EAU 2020.

If unplanned leaning in the longitudinal direction of the wall must be compensated or a connection from inclined to a vertical wall must be made, this can be done with special welded piles. The new geometry should fit under the pile driving machine. Vertical connections for piles driven at an angle always require careful three-dimensional planning.



Example for a corner of an inclined wall

### 9.10.1. Pipe connections

Where culverts or start shafts for micro-tunnels are constructed, the connection of pipes with different diameters can be challenging. The connections can be designed rigid or flexible and, if required, watertight.

The installation can be done either as one pre-assembled element or in individual parts to be assembled. Later installation through the already driven sheet pile wall is also possible.



Examples of connections through sheet pile walls

### 9.10.2. Interlocking options

All sheet pile sections from ArcelorMittal can be combined with each other, as the same Larsen interlock is rolled on all U- and Z-profiles.

If a new sheet pile wall is connected to an existing wall with a different interlock geometry, it is an option to pull out the last pile, cut-off the flange with interlock and welded the piece to the first new pile to be driven. This special pile is threaded into the old wall and driven to depth. The new sheet piles are now inserted according to plan and the wall is well connected at the joint.

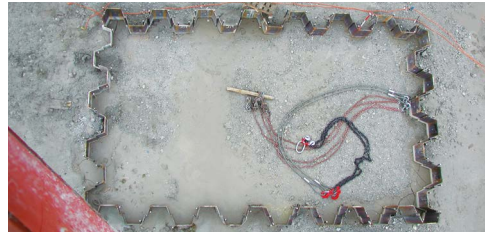

## 9.11. Enclosed cofferdams

### 9.11.1. Rectangular boxes

To install a closed box of sheet piles, two options will ensure success.

Depending on the length of the piles, the piles can be placed in a guide frame using appropriate temporary fixing. Only after the box has been closed, the piles are driven staggered, similar to the erection of circular cells. The crane boom on site must be long enough to thread the piles into the previously placed ones. It is advisable to work with a free suspended vibrator. The pile-driving depth per pile must be adapted to the existing conditions, piling should be carried out in at least two stages.

If a leader machine is available, or if the piles are very long, start placing and piling until approximately 5 piles before the corner. Work in one direction until the box can be closed. Closing can be facilitated by adjusting the wall ends inwards or outwards to the real dimensions. It is important to insert the piles plumb, especially in the corner areas. A possible tendency to lean must be corrected, if necessary with special piles.

If exact dimensions must be maintained, the use of special piles is inevitable.

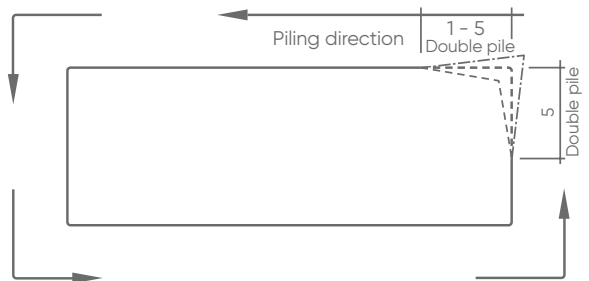



### 9.11.2. Circular boxes

The length and straightness of the piles have a significant influence on the achievable rotation between the individual piles. For the Larssen interlock, a 5 degree rotation per free interlock can be assumed, for piles with length over 20 m the value decreases to 4 degrees. On site, a higher rotation has already been achieved with appropriate use of force; however, this is not recommended. Bent piles can always be manufactured at the factory up to approx. 25 degrees. Any rotation in the interlock significantly increases the friction in the interlock and thus the driving resistance is increased.

For small-diameter circles, it is recommended, that piles are set up with the help of a guiding frame, fixed and the circle closed. Piling should then be done in stages, each time with a short offset between adjacent piles to ensure proper guidance. If the design geometry is not achievable by just rotating the interlocks, bent piles or other special piles can be used.

For large circles, staggered driving is recommended. This installation method makes it possible to maintain the vertical position of the piles and to close the circle without too much effort. It may also be necessary to close the circle by a slight increase or decrease to the radius or by inserting a manufactured special pile.

In general, Z-piles are the better choice for circular pile driving because of the external interlock position, which allows for more geometric tolerances. In addition, U-piles usually should be used as crimped or welded double piles for structural reasons, which further reduces the flexibility of the double pile.

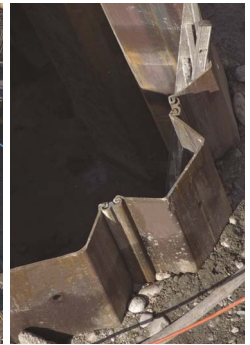
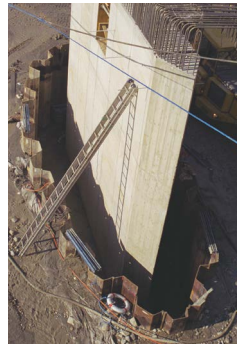

## 9.12. Head and toe reinforcements

If in the construction area the presence of obstacles is to be expected, such as stones, boulders, old concrete structures, or tree trunks, or if hard soil layers must be penetrated, or if the pile toe has to be driven into weathered rock, it may be advisable to apply toe reinforcements to the sheet pile. Special cast steel pile shoes in the shape of the section are available on the market (see picture page 56). Simple steel plates, in the same thickness as the basic sheet pile, can also be welded on one or both sides. The reinforcements provide increased rigidity to the pile, helping to penetrate difficult soils and to avoid pile deviations.

Head reinforcements by welded-on plates are an option, if there is a risk of brittle fracture in the gripping area of the clamps of the vibrator, during longer pile driving times or if deformations appear on the pile head under the impact hammer.



For the king piles of combined walls, special cutting of web and flange has shown improved drivability where piling is done in hard soil layers or in soft rock. The pile preparation can be carried out in the factory or on site. For both, single or double beams the cutting is possible. Working together with a sufficiently large impact hammer, pre-drilling may not be necessary.

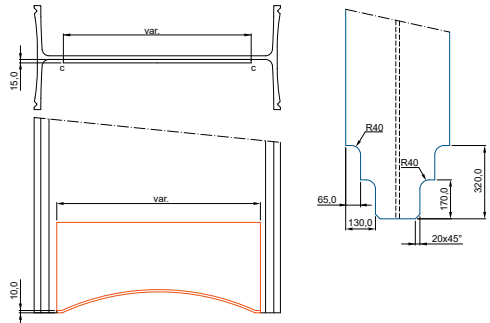

## 9.13. Piling in rock and rock dowels

Piling in rock is possible with appropriate preparation, for example in weathered rock, light sedimentary rocks such as sandstone, limestone, and siltstone with compressive strengths of no more than 5-8 MN/m<sup>2</sup>. The minimum section modulus should not be less than 3600 cm<sup>3</sup>/m.

The steel grade should be at least S355GP or higher. Toe reinforcements or prefabricated pile shoes made of hard and resistant cast steel, together with a strong impact hammer, can lead to a successful pile driving result. The ratio of impact weight to driven material plus driving cap should not be less than 2:1. Experience shows that in combined walls, HZ®-M profiles can achieve very good daily installation performance when special pile cutting is used. If pipes are installed as load-bearing elements, pre-drilling can be very effective. However, this requires increased machinery use.

If piling into the rock is not possible, rock bolts can be used to create sufficient pile toe resistance. The sheet piles are fitted with pipes of 8-10 cm diameter before installation. After installation to final depth, or if no further penetration into the ground is possible, drilling is carried out through the welded pipe into the existing rock.



The embedment depth is approx. 1-2 m depending on the static requirements, the dowel is fixed in position by injecting a



cement slurry. The minimum length of the Dowel is 2 m.

A special brochure on "Rock Bolts" is available from ArcelorMittal.

If piling in rock and dowelling do not lead to the desired success, a cofferdam made of circular cells can be considered (see chapter 10.).

## 9.14. Low temperature piling

If sheet piles are installed in cold conditions or arctic regions at permanently low temperatures below  $-5^{\circ}\text{C}$ , special recommendations should be observed.

The minimum steel grade should be at least S355GP or higher, have a notch impact strength of at least 27 kJ at  $-20^{\circ}\text{C}$ . Depending on the soil conditions, the section modulus of the sheet pile should not be less than  $1800\text{ cm}^3/\text{m}$ .

Due to its chemical composition, ArcelorMittal's AMLoCor steel grade is also well suited for low-temperature piling, as this special steel is less brittle than normal structural steel for sheet piling. Other special steels can be provided on request.



## 9.15. Interlock sealing

To achieve the required watertightness for a specific project, various alternatives to seal the sheet pile interlocks are available. The simplest option is to wait until water carrying fine particles naturally seals the interlocks after some time.

A common site application is to fill the locks with hot or cold bituminous material. Beltan has to be applied hot. The respective manufacturer's instructions must be observed. The bituminous sealant can also be used as a lubricant to reduce interlock friction during installation. Special care should be taken when using flange-based (compression) seals and hydrophilic sealants.

For flat sheet piles, it is not advisable to use sealants or lubricants, in order to maintain full tensile strength in the interlocks. A special brochure on the water tightness of sheet pile structures is provided by ArcelorMittal. For the preparation of a detailed driving plan, information on the desired sealing material, the piling direction and water level is required.

## 9.16. Tie-back connections

The anchoring of a sheet pile wall must be dimensioned and designed according to the requirements of the project. The common anchor systems are prestressed grouted anchors or passive systems with threaded bars or round steel anchors. Inclined H-piles or so-called "flap anchors" are commonly used for heavy quay walls. Watertight anchor heads may be required with high groundwater levels. An eccentric anchorage simplifies attaching to Z-sheet piles. Special catalogues with technical details on the different anchor systems are available from ArcelorMittal.

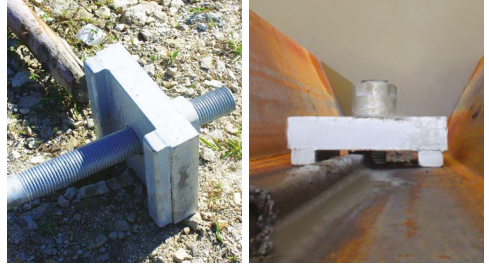

Classic anchor connection for Z-piles

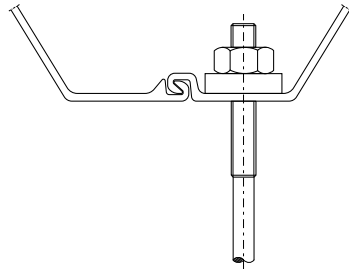

Eccentric anchorage for Z- piles



U-piles with waling along a railway line



U-profile as waling for temporary piles

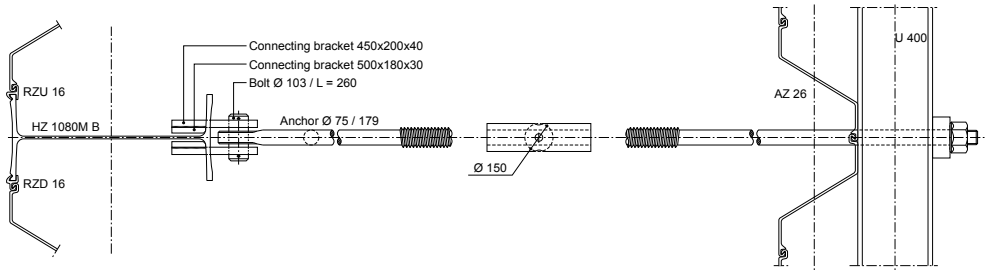

Example for a hinged HZ®-M connection (left) and sheet piling with waling (right)



Watertight connection for a grouted anchor

A detailed recommendation with general design approval for “knife edge support” is available from ArcelorMittal, together with a program for dimensioning the capping beam. The main field of application is hydraulic structures, or foundations of buildings and bridges where the sheet pile wall is used as permanent foundation element to transfer large vertical loads.



Inclined pile connection



Cover with steel profile

## 9.17. Sheet pile capping beams

After piling is finished, it may be necessary to cover the sheet pile wall. Prefabricated elements made of steel or reinforced concrete can be used. Coating is possible if required. An in-situ concrete capping beam can also be produced using appropriate system formwork.





Bridge abutment with load introduction of vertical and horizontal forces

## 9.18. Measurements on existing structures

To be able to make statements about the stability of an existing structure, it is necessary to know the profile type, the steel quality, and the profile length. If no documentation on an existing structure is available, special non-destructive measuring methods can be used to make at least a basic statement about wall thickness or profile length.

The remaining wall thickness can be determined with the help of ultrasonic equipments. The measurements can be carried out both above and under water. To keep execution errors as small as possible, the measuring head must be carefully attached to the wall and the surface should be clean. If measuring is carried out at intervals of several years, care must be taken to ensure that measurements are always done at the same place.

The determination of the length of a driven sheet pile in the ground can be determined via seismic measurements with sufficient accuracy (<0.5 m).

If elaborate measurement campaigns or major repairs on harbour walls are required, mobile docks can be used to dry out parts of a wall.

## 9.19. Box piles

Steel sheet piles can be assembled very easily into systems with high bending moment capacity. Z- and U-sheet piles can be combined into welded box sections.

This can also be done subsequently on site, if the static requirements have changed at short notice. In combination with normal sheet piles as intermediary piles, very cost-effective combined walls can be produced.

Installation is as described in chapter 4.4. and 5.5. by vibro or impact hammer.



Z-box pile wall (CAZ): Design possible with intermediary piles or as a pure box pile wall

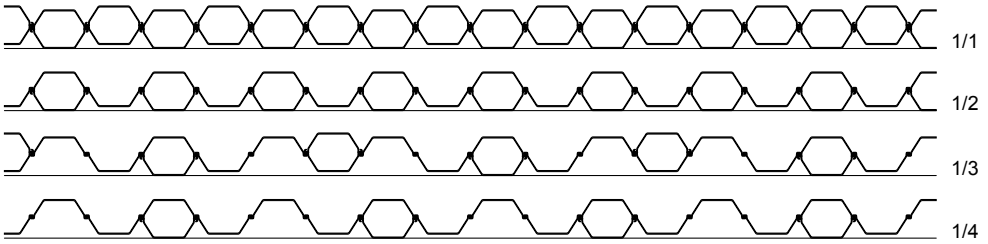

U-box pile wall in different design options

The advantage of a box pile is that interlocks are already in place and the system spacing corresponds to the one of a standard sheet pile wall. Further advantages can result from optimized transport, if the sections are welded into box piles on site. The splicing of piles to longer lengths is easily possible.

CAZ piles have been installed in lengths of over 70 m. Most box piles are used without anchors, as the high inertia allows construction of a cantilever wall.

Anchor connections require careful planning to ensure ease of installation on site.

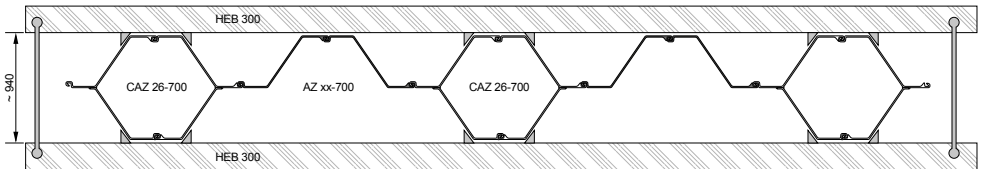

Example of a CAZ ramming guide



Completed CAZ box pile wall



CAZ storage area

## 9.20. Welding and butt joints

Welding of brackets, armour plates and other components, as well as the subsequent extension of sheet piles, HZ®-M piles or HP piles, for example after a load test, is possible on the construction site. The welders must have the appropriate qualifications and the relevant local standards and regulations must be observed.

Further information can be found in the EAU 2020 (chapter 8.1.4.2.) or in the ArcelorMittal brochure "Welding of steel sheet piles".



Example of a construction joint



Aligning the interlock position to allow sliding of profiles after welding

## 9.21. Working direction of piling

Contrary to sheet piles with ball-and-socket-interlock, there is no preferred driving direction for the Larssen interlocks used by ArcelorMittal. However, the straight interlock is often driven first, as double piles in Form I are chosen as standard.

It should always be checked before installation that the form supplied corresponds to the driving plan specification.

If corner sections are to be installed, they should always be fixed to a sheet pile and serve as a threading interlock for the next pile. A single corner profile does not have sufficient stiffness for driving and usually cannot be installed without additional support.

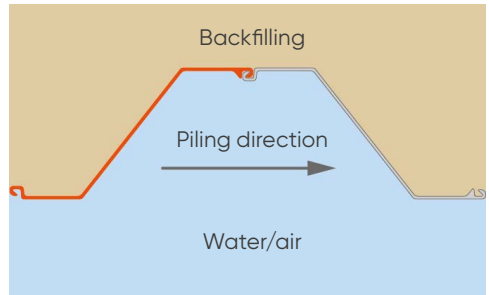

Double pile Form I: Standard

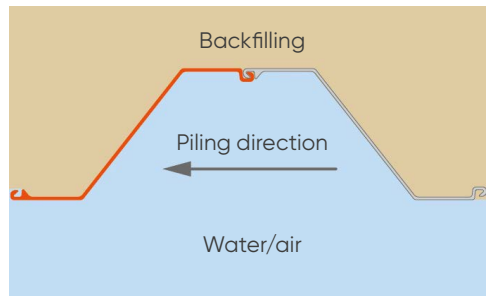

Double pile Form II: on request

# 10. Flat sections AS 500®

## 10.1. General information

Flat cell constructions are often used when very hard soil layers prevail and piling into the ground is not possible. Due to the weight of the filled cell, sufficient stability is achieved. Both, permanent and temporary structures are possible. Extracted sheet piles can be reused. Flat sections are intended for the construction of circular cofferdams. Where the tensile forces are exceeding the capacity of the flat profile, a change towards a flat cell design might be required. The nominal width of the profiles is 500 mm.

The individual profile types differ in material thickness (9.5–13.0 mm) and the permissible tensile strength of the connecting locks. For dimensioning the required outer diameter of the piling frame, a nominal profile width of 503 mm should be assumed. This guarantees that the diameter is sufficient to close the cell before the actual pile driving. The flat pile is the only type of sheet pile that must have a specified interlock tensile strength. ArcelorMittal can offer values of up to 6000kN/m.

In very soft soils, cell construction can be useful to create a stable structure by soil improvement within the cell.

Cell solutions can be optimized by installing the intermediary cells only one sided to the front of the wall or by shortening the piles staggered to the back. So-called open cell constructions are only recommended in connection with intensive soil investigation, and they are not suitable for earthquake areas.

Depending on the pile length, a theoretical interlock rotation angle of 4.0–4.5° can be assumed.

## 10.2. Storage

Due to their low inertia, flat profiles must be stored, transported, and picked up carefully. Two or more lifting points must be considered, depending on the length of the pile. Incorrect storage or incorrect lifting can cause permanent deformations that make it difficult, or in the worst case impossible, to use the pile later on the job.



If the piles are stacked on top of each other, all timbers placed in between should be aligned vertically. Unevenly distributed spacers can lead to plastic deformation.

The height of the pile stacks should be adapted to the load-bearing capacity of the ground.

Coated piles must always be treated with utmost care, repair paint can be supplied on request.

### 10.3. Transport



For loading flat profiles, spreader beams or special fabricated profile sections should be used. In special cases, pile packages can be assembled in the factory which provide sufficient security against damage during the transport.

### 10.4. Lifting



Piles up to a length of approx. 15 m can be lifted at the top for threading. The pile head can be fixed using the factory-made handling hole. Longer piles should be supported on two or three points to prevent plastic deformation due to overstressing.

The use of double or even triple piles can be advantageous, as they provide more stability than single piles. In addition, the installation time is shortened as multiple piles are threaded per working sequence.

Vibratory hammers with multiple clamps for simultaneous installation of several sheet piles are available.

### 10.5. Installation procedure

#### 10.5.1. Guiding frame

For placing and piling of flat profiles special care is required, as they are prone to buckling and bending. Guiding constructions should be adapted to the shape of the cell and have at least two guiding levels. The individual piles must be fixed to the guide temporarily until the cell is closed. It is advisable to start with the junction piles. To allow for easy checking of the geometry, the position of the individual piles should be marked on the guide frame.

The construction of the frame depends on the size of the cofferdam and the site conditions. The guide can be positioned in water and prefabricated on land. It is important that the different guiding levels can be moved vertically, so that pulling upward is possible when backfilling the cell. The guide levels can be designed as a working platform for the crew (see also chapters 4.5. and 4.6.).

#### 10.5.2. Placing the sections

After the guiding frame is securely fixed and positioned correctly, the piles are placed around the working platform and fixed temporarily until the cell is closed. Only then pile driving will start, alternating in sections of 1.0 m to 1.5 m. The limited pile driving length ensures mutual guidance of the piles and prevents the toe of the pile from deviating from plan position.



Permanent control of verticality is extremely important and ultimately saves time during the erection of the cell. Accurate and plumb positioning of the junction piles helps to stay within the required installation tolerances. The piles should be placed starting from two adjacent junction piles, working towards the middle. The last pile or pair of piles is used to close the arch, as the greatest flexibility is provided at the middle point.

Before filling the circular cell, the first two to three piles of the intermediary arc must be placed in the junction pile, as later threading might become difficult by the unavoidable widening of the cell (barrel effect). A cell always consists of an even number of profiles.



### 10.5.3. Pile driving

The profiles are best installed by a vibrator or light impact hammer, depending on the soil conditions. In any case, the equipment should be light and easy to handle, to facilitate staggered and alternated piling. The use of double piles or triple piles may be advisable as the pile driving energy is distributed over a larger area.

Depending on the ground conditions, drilling or water jetting can be foreseen to improve pile driving.



After completion of the cell, all unsuitable soil, like mud or organic material, should be removed and filling the cell can start with well graded and compactable material. Once the fill has reached a safe level, the guide frame can be lifted out and moved to the next working position.

## 10.6. Dismantling of cells

The dismantling of cell constructions is done in the reverse order to the construction. In a first step, approximately one third of the cell fill is excavated, then the guide frame is reinserted to stabilize the cell for deconstruction. This is followed by further excavation. As a minimum the junction piles should be fixed to the guiding frame to prevent uncontrolled behavior of the remaining cell, as once the first flat pile has been extracted the ring forces are gone and the piles lose their supporting stability. Filling should be removed as far as possible to reduce the ring forces as best as possible. Multiple use of the removed piles is possible. The material must be visually inspected for damage and repaired, if necessary. If reuse is not intended, the cell can also be dismantled by partial dredging and subsequently cutting the piles for scrap.



## 10.7. Productivity assumptions

To estimate the time required to construct a cell, the boundary conditions of the construction site must be considered. In particular, the geographical location of the site, wind loads, swell, currents above and below water, installation from land or water and the available equipment technology have a significant influence on the working performance.

Example for estimating the construction time for a circular cell with 12 m diameter and sheet pile length of 16 m, installation in water:

- Positioning and fixing of the guide frame ~1,5 days
- Positioning, aligning and temporary fixing of the piles until cell closure ~ 2 days
- Alternating pile driving to target depth in maximum 1m increments ~ 1 day
- Backfilling of the cell and dismantling of the guide frame for repositioning ~1,5 days

The next cell is built according to the same schedule. The intermediary cells are normally not on the critical path for the construction schedule.

# 11. Extracting sheet piles

## 11.1. General information

Sheet piles can be extracted at the end of their use with suitable methods and equipment, even after a long time in the ground. As a rule of thumb, the same energy is needed to remove the piles, as was needed for their installation.

Reuse of the extracted piles is possible, with only small losses due to trimming deformed pile heads or toes to consider.

## 11.2. Pile preparation

If extracting the sheet piles after use is foreseen, the work should be planned in detail in advance and included in the construction sequence. Influencing factors are profile type, pile length, driving depth, soil conditions, service life in the soil, driving method and possible reuse.

To reduce friction and prevent the interlocks from clogging making them difficult to move over time, it is recommended to fill the locks with grease or Beltan® Plus or other lubricating material. Any larger interlock rotation required by plan, should be executed using special piles to ensure optimum alignment of the threading interlock, thus minimizing friction.

In dense soils, the use of piling shoes can make extraction easier. The driving shoe is placed at the pile toe immediately before driving and not welded to the pile. The pile shoe covers slightly more surface than the sheet pile and creates a loosened zone along the pile surface during driving.

Utmost verticality of the pile in the ground facilitates the pulling process. To achieve this, a sufficiently rigid profile and suited piling method should be chosen.

To estimate the energy required for the pulling work, it is useful to establish a pile driving report for each pile. In the best case, the driving reports indicate the piles that are expected to offer the least resistance for pulling. If no driving reports of the sheet piles are available, the first pile to be pulled should be carefully selected. A randomly chosen pile in the middle of the wall can be used to start, until a pile is found that moves.

If an underwater concrete slab is poured against a temporary sheet pile wall, it can be assumed that the horizontal component of the vibration force is sufficient to loosen the bond between the hardened concrete and steel. For a slab thicknesses between one and two metres it should be no problem to pull the sheet piles out. If the concrete structure is constructed along the sheet pile wall over a longer area, it is advisable to insert a separating layer of plastic between the concrete and steel, and to fill the sheet pile valleys facing the concrete structure with gravel or other movable material. When extracting the piles, this material will close the minimal gap between the soil and the structure.

As a calculation value for the friction between a concrete slab and a sheet pile wall, 100–1500 kN/m<sup>2</sup> can be assumed from experience, always depending on the local boundary conditions, the surface condition and the driving tolerances.

### 11.3. Extraction procedure, estimation of forces

Vibrators and special pile extractors of different sizes are available for extracting sheet piles. They loosen the pile in its actual position and together with the pulling force of the crane, cause the pile to move. The size of the pulling equipment should not be smaller than the one used for initial piling. It is essential for safety not to exceed permissible forces according to the specifications of the equipment manufacturers.

A vibrator is connected to the pile by hydraulic clamps, for the extractors, special clamping tongs or grippers with bolts can be used. Heavy pulling work might require reinforcements on the sheet pile head.

If the first pile in a wall cannot be loosened just by vibration, hitting it with an impact hammer may loosen the bond between the sheet pile and the soil.

Pre-augering near the pile might lead to relaxing the soil, also water jetting can be helpful. Cooling the locks with water is recommended during pulling, especially when smoke is visible.

The necessary pulling force on the crane can be estimated using the following formula:

$$F_{\text{pull}} = [(G_V + G_R) \cdot g] + \frac{(R_M \cdot A)}{10}$$

Whereby:

$F_{\text{pull}}$	= Force on the crane hook	in kN
$G_V$	= Weight vibrator	in kg
$G_R$	= Weight of pile	in kg
$g$	= 9,81	in m/s <sup>2</sup>
$R_M$	= Skin friction pile-soil	in kN/m <sup>2</sup>
$A$	= effective surface sheet pile	in m <sup>2</sup>

To cater for the influence of the Interlock friction and as an additional safety factor, a certain percentage should be added to  $F_{\text{pull}}$ . The load limits of the equipment used must be observed.

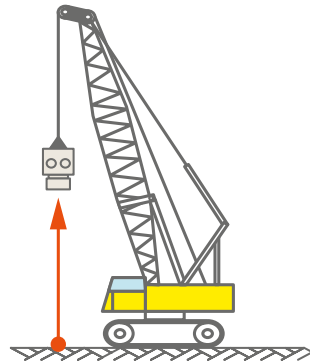

Pulling sheet piles, schematic drawing

## 11.4. Electro-Osmosis

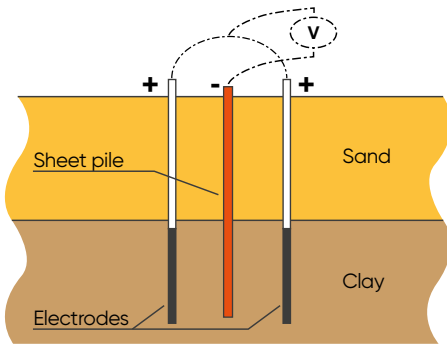

Theory of electro-osmosis

In cohesive soils, the pulling resistance can become very high after some time. During service life, the soil has “grown” on the sheet pile and a strong bond is formed with the piling material. The well-known effect of electro-osmosis can be used to drain cohesive soil types. If the effect is reversed, the trapped pore water is enriched along the sheet pile wall, leading to a lubrication and thus reduction of resistance against extraction.

Research projects are currently underway to make the method usable for construction practice.

## 11.5. Reuse of sheet piles

All sheet piles are suitable for multiple reuse, especially U-profiles as single or crimped double piles, which are often installed as temporary piles. The reinforced corners of the U-profile provide excellent piling stability with reduced wear per use. The choice of a higher steel grade will be beneficial on the service life, also a minimum section modulus of  $1800\text{cm}^3/\text{m}$  should be considered. Depending on the soil conditions and piling method, five to ten installation cycles may be possible.

Repair measures and length reductions by trimming deformed pile ends should be taken into account. Filling the threading interlocks before use also has a positive effect on the service life of the temporary sheet piles (see chapter 7.5.).

Used piles should comply with the dimensional tolerances of EN 10248-1/2, the locks should be intact and free-sliding, and contain no obstructions.

In terms of the circular economy, steel sheet piles are always a long-lasting and cost effective solution for all types of civil engineering and hydraulic engineering projects.







Sheet pile wall work at Frankfurt Airport

## 12. Repair works

In most cases, undetected obstacles in the subsoil are the cause of excessive deformations and subsequent interlock damage. In rare cases, systematic installation errors may be encountered, or fine sand trapped and consolidated in the Larssen interlock blocks the piles to be installed. Countermeasures are described in chapter 7.5. Further basic information can be found in chapter 8.1.8. of the EAU 2020.

### 12.1. Deformations at pile head

In the case of very long vibration times with only small driving progress or in the case of very heavy impact pile driving, the head of the sheet pile may be plastically deformed or, in the worst case, brittle fracture may occur due to overstressing. Rupture in this case generally is visible around the clamping area and passing through the handling hole of the sheet pile.

The deformed or cracked part of the sheet pile should be removed by cutting. If the installation of a capping beam is planned in the further course of the work, Chapter 8.1.4.4. of EAU 2020 ("Cutting off the head ends of driven steel sections") should be observed. Corresponding length allowances should be foreseen and added to the initial design calculation of sheet pile wall. Worn-off clamping surfaces must be replaced in time to avoid excessive stress introduction on the pile head during vibration.

## 12.2. Interlock damages

If interlock damage has occurred within a sheet pile wall, despite problem-free construction execution, its location and size should be well documented to determine the most suitable repair method. Overall, the repair of steel walls is relatively easy to do.

Steel plates can always be welded in affected areas, even under water, to prevent soil loss and subsequent surface settlements. A sheet pile wall can also be driven in front of the damaged area and the remaining space is filled with concrete. Behind the wall, HDI (high pressure injection) columns are an effective option to restore the wall integrity. Extracting and reinstalling undamaged replacement sections can be considered. Avoiding head deformations is described in chapter 12.1.

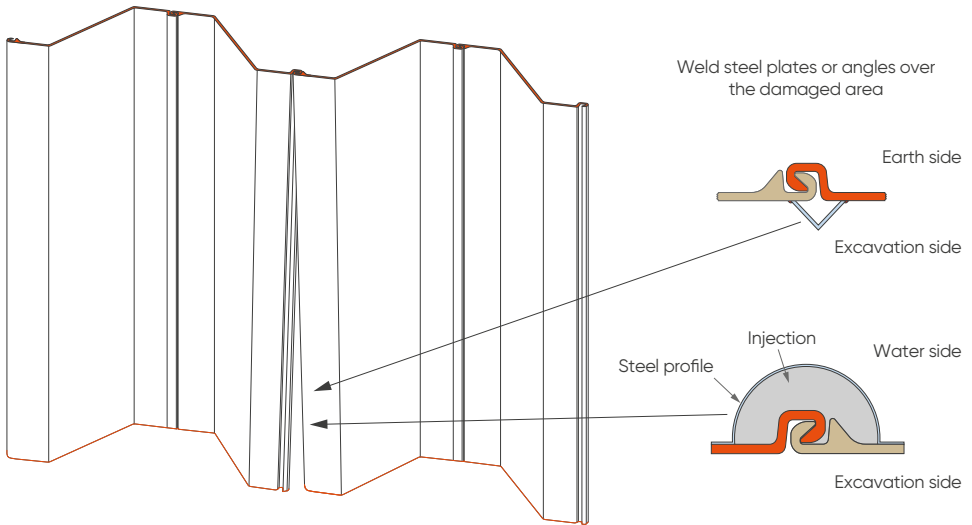

Repair options for interlock damages

# 13. References

## Literature:

Vibrofonçage, Guide Technique 2016

DIN EN 12063 edition 1999-05/2023 : Execution of special geotechnical works - Sheet pile constructions

Technical European Sheet Piling Association (TESPA) manual on the installation of steel sheet piling.

DIN EN 10248-1, DIN EN 10248-2 Edition 1995-08 Hot-rolled sheet piles of non-alloy steels

Part1: Technical delivery conditions

Part2: Tolerances on shape and dimensions

EAU 2004, EAU 2012, EAU 2020 and associated annual reports

EA Pfähle, 2nd substantially revised and expanded edition January 2012, 2022 and associated annual reports.

Knife edge bearing Z\_15.6-235

CUR (interlock protection)

## Copyrights:

ABI GmbH, Niedernberg, Germany

ArcelorMittal Sheet Piling

Bauer-RTG

Birmingham Hammer

Dawson Construction Plant Ltd, Milton Keynes, UK

Delmag

Dieseko

D & K Spezialtiefbau

Giken Europe B.V.

IHC-IQIP

Liebherr, Nenzing

Menck

Pajot

PTC

© BMGS











© Puerto Angamos



©B&K



Earth dyke reinforcement, Germany

Issue 09.2024

### **Disclaimer**

The data and commentary contained within this steel sheet piling document is for general information purposes only. It is provided without warranty of any kind. ArcelorMittal Commercial RPS S.à r.l. shall not be held responsible for any errors, omissions or misuse of any of the enclosed information and hereby disclaims any and all liability resulting from the ability or inability to use the information contained within. Anyone making use of this material does so at his/her own risk. In no event will ArcelorMittal Commercial RPS S.à r.l. be held liable for any damages including lost profits, lost savings or other incidental or consequential damages arising from use of or inability to use the information contained within. Our sheet pile range is liable to change without notice.

Printed on FSC paper. The FSC label certifies that the wood comes from forests or plantations that are managed in a responsible and sustainable way (the FSC principles promote the social, economical, environmental and cultural needs of today's and the next generations).  
[www.fsc.org](http://www.fsc.org)



**ArcelorMittal Commercial RPS S. à r.l.**

Sheet piling

66, rue de Luxembourg

L-4221 Esch sur Alzette (Luxembourg)

[sheetpiling@arcelormittal.com](mailto:sheetpiling@arcelormittal.com)

[sheetpiling.arcelormittal.com](http://sheetpiling.arcelormittal.com)

 Hotline: (+352) 5313 3105

 ArcelorMittalSP

 ArcelorMittal Sheet Piling (group)